



Finishes You've Never Seen Before®

WESTERN STATES METAL ROOFING

(877) 787-5467 • WESTERNSTATESMETALROOFING.COM

BOARD & BATTEN

INSTALLATION GUIDE WITH TRIM, FLASHINGS AND DETAILS



Phoenix: ☎ (602) 495-0048 ✉ sales@westernstatesmetalroofing.com | Washington: ☎ (509) 418-2833 ✉ washington-wsmr@westernstatesmetalroofing.com

Tucson: ☎ (520) 574-4247 ✉ tucsonsales@westernstatesmetalroofing.com | Texas: ☎ (972) 843-4343 ✉ texas-sales@westernstatesmetalroofing.com

Western States Metal Siding "Board & Batten" Panel

Installation, Flashings & Shop Drawing Detail Guide

Table of Contents

Section	Page
Notes to Designer /Installers.....	1
Key Wall Plan.....	2
Fastener Selection.....	3-4
Screw Fastener Notes.....	5
Panel Profile.....	6
Key Flashing / Trims	6-8
Soffit End Splice Detail	9
Wall Soffit End Splice	10
Soffit End Wall	11
Alternate Soffit End Wall	12
Soffit To Wall Drip Op 1,2.....	13-14
Horizontal Siding Endwall.....	15
Vertical Siding Endwall Op 1,2.....	16-17
Parapet Wall	18
Wainscot Transition BB to PBR.....	19
Vertical Base.....	20
Window / Door Head.....	21
Window / Door Jamb Op 1,2.....	22-23
Window / Door Sill.....	24
Transition BB - 7/8" Corrugated.....	25
Transition BB - Western Rib.....	26
Transition BB - Western Reveal.....	27
Transition BB - Rustwall.....	28
Transition BB - Western Wave.....	29
Transition BB - Western Lock	30
Transition BB - Western Seam 1.5	31
Transition BB - Western Seam 1.0	32
Soffit To Wall Horizontal.....	33
Parapet Wall Horizontal	34

Section	Page
Horizontal Base	35
Head Trim Horizontal	36
Jamb @ Window / Door Horizontal	37
Jamb @ Window / Door Vertical	38
Window / Door Sill Horizontal	39
Transition BB - 7/8" Corrugated Horizontal	40
Transition BB - Western Rib Horizontal	41
Transition BB - PBR Horizontal	42
Transition BB - Western Wave Horizontal	43
Transition BB - T-Groove Horizontal	44
Transition BB - Western Reveal Horizontal	45
Outside Corner Op 1.....	46
Inside Corner Op 1.....	47
Outside Corner Op 2.....	48
Inside Corner Op 2.....	49
Custom Trim Sheet	50
Notes	51

Western States Metal Siding "Board & Batten" Panel

Installation, Flashings & Shop Drawing Detail Guide

Notes to Designer and Installers

The details contained in this guide are proven industry details and are intended to be used as a design aid and installation guide. It does not depict all situations that may be encountered on all projects. Modifications are the responsibility of the designer/ owner/ installer. Consideration should be given for fit for purpose, building use, climate conditions such as temperature, snow, wind, and moisture, governing building codes, and maintenance. It is highly recommended that all trims and flashings be of the same material as the panels (metal, gauge, finish) to ensure long term performance and durability. Where possible, flashing edges should be hemmed to strengthen the edge and protect the cut edge from exposure.

Framing and Substrates

"Board & Batten" panels are used over all type of substrates like steel framing, open purlins, spaced sheathing, and wood surface such as plywood. Most details in this guide are shown with panels attached to open framing.

Note on Underlayment

Not all conditions require an underlayment, however, metal siding is susceptible to condensation and it is recommended that an appropriate underlayment be use on all wood substrates to protect the structure during installation. For added protection from rain and snow, it is recommended to use rubberized ice and water shield.

Technical Assistance

Contact your WSMR sales or technical representative for any additional information or assistance.

Oil Canning

Oil canning is a condition common with flat metal surfaces. This waviness is caused by steel mill tolerances, forming, variations in the structures surfaces, and hardness of the steel. Measures are taken at the roll forming process, like profile design, steel gauge, corrective leveling, to minimize the effects of oil canning. Oil canning is a characteristic of steel and can not be eliminated totally and therefore is not reason for rejection of the panels.

Job Site Storage

While waiting to be installed on the job site, storage of panels, trim crates, and flat sheet should be sloped in order to allow for proper moisture run off. One end should be elevated so as not to allow ponding of water on the metal surface. When using tarps for protection, proper ventilation should be provided to prevent condensation. Moisture or condensation that is trapped inside a bundle can lead to white rust on sheeting. WSMR assumes no responsibility of liability for damage to our products which occurs in the possession of the consignee or which we deem to be improper handling and storage. Protective plastic film on trim or panel should be removed within 90 days. Failure to follow these instructions may void the warranty.

References

For other installation techniques and details, The Sheet Metal and Air Conditioning Contractors National Association Inc. (SMACNA) and NRCA manuals are great resource for working with sheet metal.

FLASHING TYPE

DETAIL NO.

STANDARD TRIM	WSD-ST1
STANDARD TRIM	WSD-ST2
STANDARD TRIM	WSD-ST3
SOFFIT END SPLICE	WSD-W1
WALL-SOFFIT END SPLICE	WSD-W2
SOFFIT END WALL	WSD-W3
ALTERNATE SOFFIT END WALL	WSD-W4
SOFFIT TO WALL DRIP Op1	WSD-W5
SOFFIT TO WALL DRIP Op2	WSD-W6
HORIZONTAL SIDING END WALL	WSD-W7
VERTICAL SIDING END WALL Op1	WSD-W8
VERTICAL SIDING END WALL Op2	WSD-W9
PARAPET WALL	WSD-W10
WAINSCOAT TRANSITION TO PBR	WSD-W11
VERTICAL BASE	WSD-W12
WINDOW/DOOR HEAD	WSD-W13
WINDOW/DOOR JAMB Op1	WSD-W14
WINDOW/DOOR JAMB Op2	WSD-W15
WINDOW/DOOR SILL	WSD-W16
TRANSITION BB - 7/8" CORR.	WSD-W17
TRANSITION BB - WESTERN RIB	WSD-W18
TRANSITION BB - WESTERN REVEAL	WSD-W19
TRANSITION BB - RUSTWALL	WSD-W20
TRANSITION BB - WESTERN WAVE	WSD-W21
TRANSITION BB - WESTERN LOCK	WSD-W22
TRANSITION BB - WESTERN SEAM 1.5	WSD-W23
TRANSITION BB - WESTERN SEAM 1.0	WSD-W24
SOFFIT TO WALL HORIZONTAL	WSD-W25
PARAPET WALL HORIZONTAL	WSD-W26
HORIZONTAL BASE OP 1	WSD-W27
HEAD TRIM HORIZONTAL	WSD-W28
JAMB @ WINDOW/DOOR HRZ.	WSD-W29
JAMB @ WINDOW/DOOR VERTICAL	WSD-W30
WINDOW/DOOR SILL HORIZONTAL	WSD-W31
TRANSITION BB - 7/8" HORIZONTAL	WSD-W32
TRANSITION BB - WESTERN RIB HRZ.	WSD-W33
TRANSITION BB - PBR HRZ.	WSD-W34
TRANSITION BB - WESTERN WAVE HRZ.	WSD-W35
TRANSITION BB - T-GROOVE HRZ.	WSD-W36
TRANSITION BB - WESTERN REV. HRZ.	WSD-W37
TRANSITION BB - WESTERN REV. HRZ.	WSD-W38
OUTSIDE CORNER	WSD-W39
INSIDE CORNER	WSD-W40
OUTSIDE CORNER OP2	WSD-W41
INSIDE CORNER OP2	WSD-W42
CUSTOM TRIM SHEET	WSD-N43
NOTES	WSD-CT44

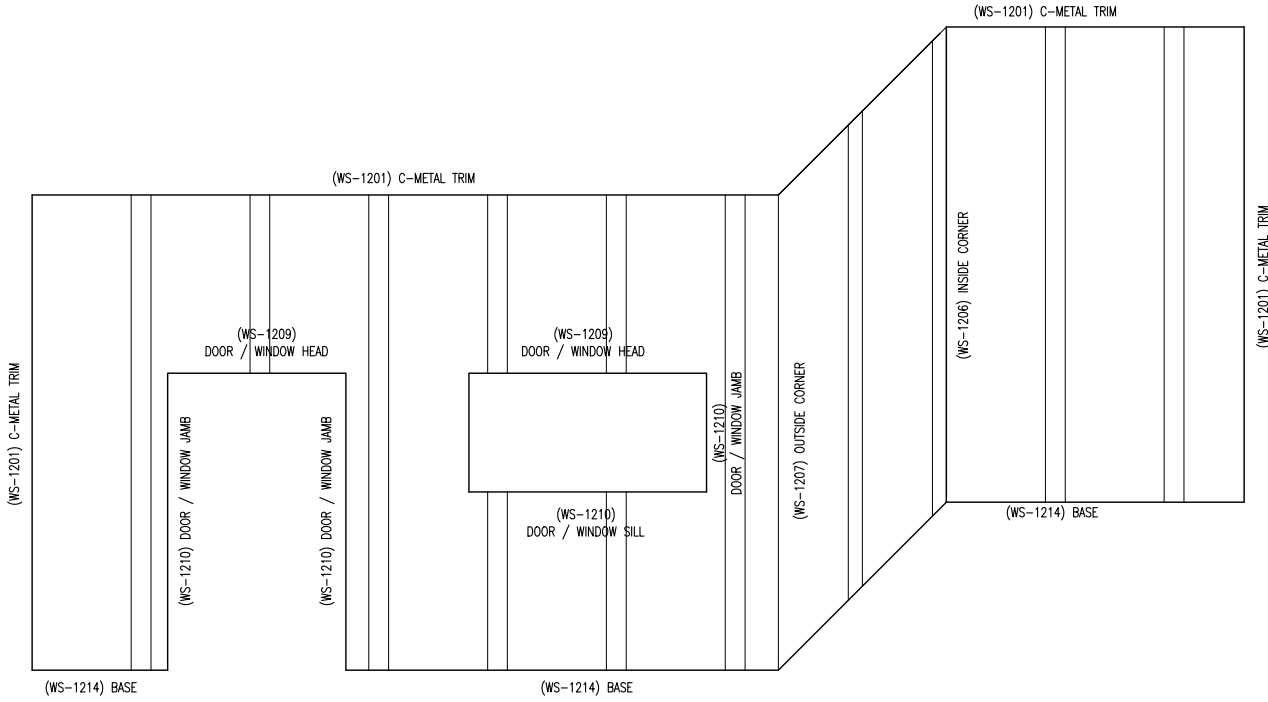

Western States Metal Roofing

901 W. Watkins St.
 Phoenix, AZ 85007
www.westernstatesmetalroofing.com

Phone: (602) 495-0048
 Fax: (602) 261-7726
 877-PURLINS (787-5467)



STANDARD TRIMS			
PANEL TYPE: BOARD AND BATTEN		A	07-18-2023
		REV:	DATE:
		DETAIL #: WP-WSD-ST1	

Western States Metal Siding "Board & Batten" Panel

Installation, Flashings & Shop Drawing Detail Guide

Fastener Selection

Notes to Installers:

Fastener Selection will vary depending on type and thickness of substrate.

Design calculations for fastener spacing should be completed by the design engineer. The use of butyl tape mastic, butyl sealants and curing sealants is always recommended to insure weather tight installation.

Panels and flashings should never be installed in contact with dissimilar metals.

Use only those flashings and accessories designed for use with this panel.

Screws must be long enough to fully penetrate through roof deck substrate or penetrate solid lumber at least one inch.

Exposed trim fasteners should have sealing washers and be coated to provide protection against corrosion.

Screws must be properly driven to ensure holding strength and proper seal. (See diagram)

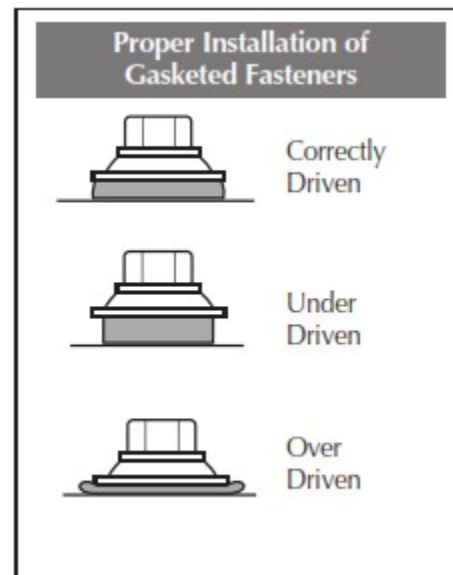

Recommended drill speed is 2000rpm. Improper setting of drill speed can lead to snapping of screw heads. Pre drilling of screw holes may be necessary with heavy gauge metals.



Western States Metal Siding "Board & Batten" Panel

Installation, Flashings & Shop Drawing Detail Guide

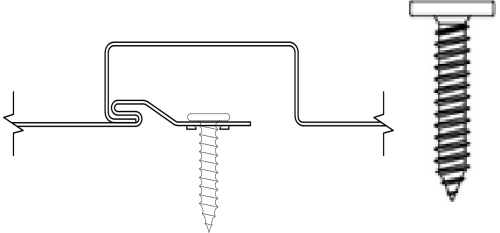
Fastener Selection

Description	Application	
14 x 7/8" Lap Self tap	Used for Trim to Trim Attachment or Trim to Wall Panels.	
#10-12 x1" Pancake head Wood	Used to Attach Panel	
#10-12x1" SD PH Self Driller Steel		
1/8" Stainless Rivets	Used for Trim to Trim Attachment or Trim to Wall Panels.	

The table above shows the panel fasteners provided by WSD. Special order screws are available.

WSMR will not be responsible for final screw selection. This guide is just a reference tool to be used. Please consult a design engineer for load and design calculations.

1" x 3/16" SLOT SPACED EVERY 6 3/8"
(THESE TOLERANCES ARE ±1/16")

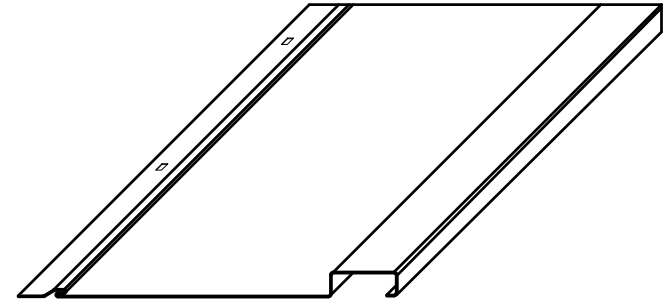
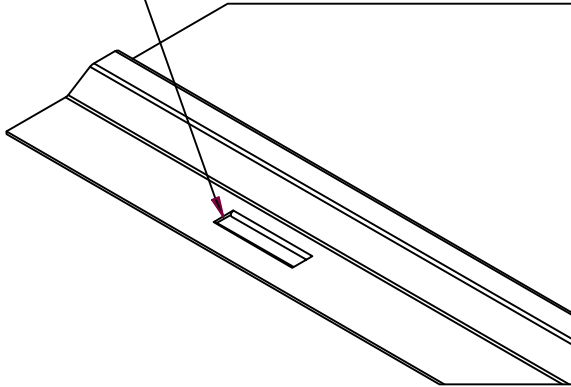

BOARD AND BATTEN			
PANEL NAME	BOARD COVERAGE	BATTEN COVERAGE	OVERALL COVERAGE
BB-20®	18"	2"	20"
BB-18®	16"	2"	18"
BB-16®	14"	2"	16"
BB-14®	12"	2"	14"
BB-12®	10"	2"	12"
BB-10®	8"	2"	10"

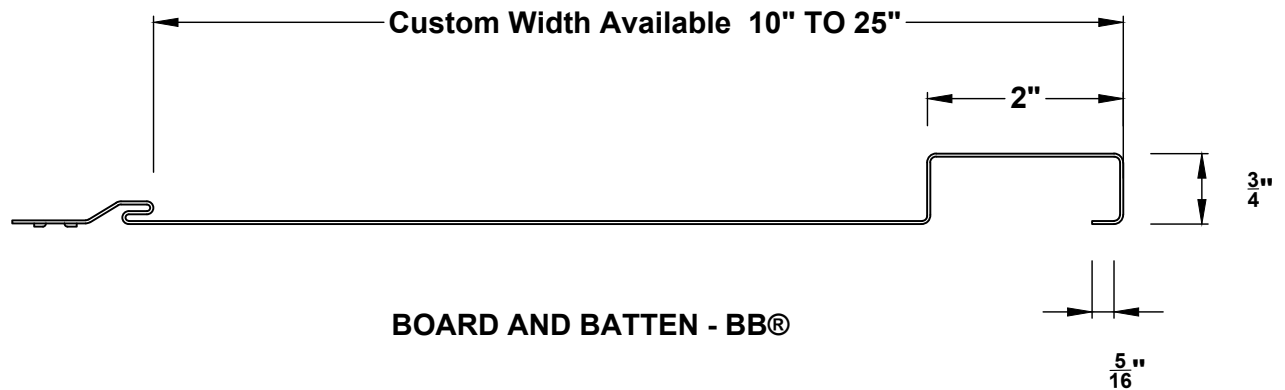

Available Lengths: 1'-0" to 30'-0" Max

Western States Metal Roofing	SCALE:	TITLE / PART NAME:		
	DRAWN:	BOARD AND BATTEN		
	DATE:	PRODUCT / PRODUCT LINE		
901 W. Watkins St. Phoenix, AZ 85007	CHECKED:	BB ®		
	DATE: 6/1/2023	PART I.D.	REVISION	SHEET
			1	

Copyright: The design and print is the property of Western States Metal Roofing, and must not be used, reproduced, or copied, wholly or in part without the written permission from the company. Supply of this design and print represents a confidential communication between the company and recipient.

<p>END SPLICE WS-1200</p>	<p>C METAL (J-TRIM) WS-1201</p>	<p>REVEAL FLASHING WS1202</p>	<p>SILL DRIP TRIM WS-1203</p>
<p>ALTERNATE SILL DRIP TRIM WS-1204</p>	<p>Z METAL TRIM WS-1205</p>	<p>INSIDE CORNER TRIM WS-1206</p>	<p>OUTSIDE CORNER TRIM WS-1207</p>
<p>TRANSITION/SILL TRIM WS-1208</p>	<p>DOOR/WINDOW HEAD TRIM WS-1209</p>	<p>DOOR/WINDOW JAMB TRIM WS-1210</p>	<p>PARAPET CAP WS-1211</p>



Western States Metal Roofing

901 W. Watkins St.
Phoenix, AZ 85007
www.westernstatesmetalroofing.com

Phone: (602) 495-0048
Fax: (602) 261-7726
877-PURLINS (787-5467)



STANDARD TRIMS

PANEL TYPE:
BOARD AND BATTEN

A	07-18-2023
REV:	DATE:
DETAIL #:	WP-WSD-ST1

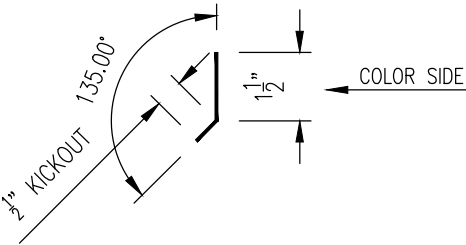
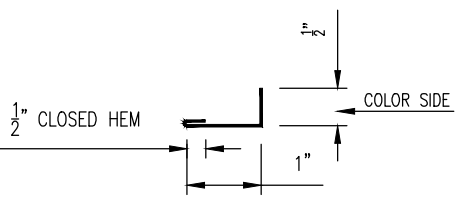
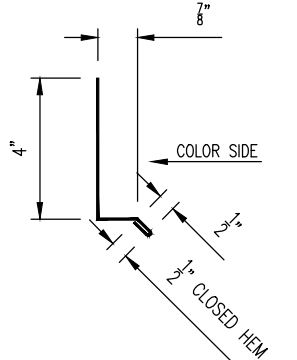
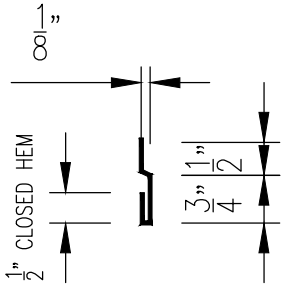
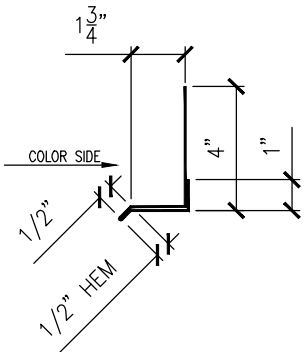
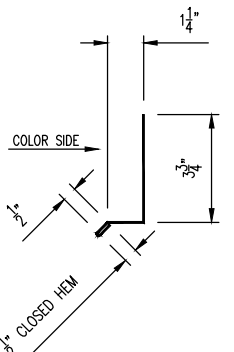
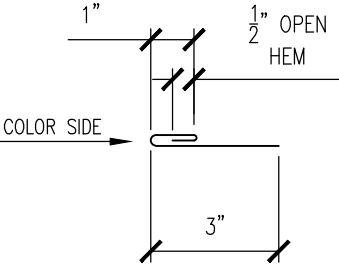
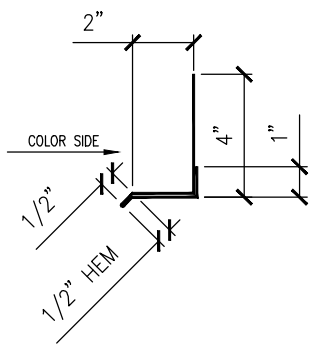
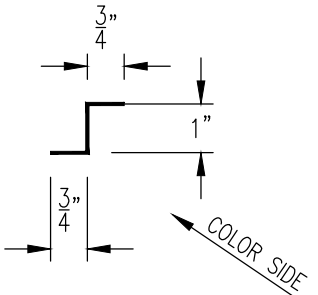
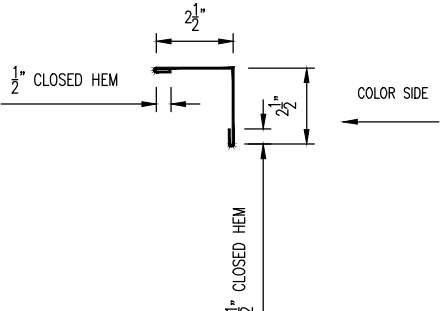
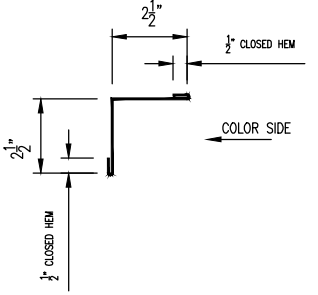
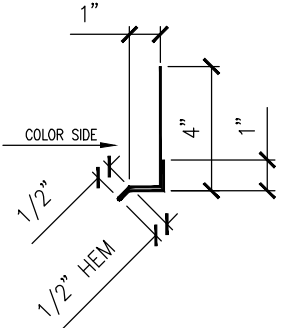
<p>TRIM CLEAT WS-1212</p> 	<p>ALTERNATE WALL TRIM WS-1213</p> 	<p>BASE TRIM WS-1214</p> 	<p>SPRING CLEAT WS-1215</p> 
<p>BASE TRIM WS-1216</p> 	<p>BASE TRIM WS-1217</p> 	<p>GABLE STARTED TRIM WS-1218</p> 	<p>BASE TRIM WS-1219</p> 
<p>Z TRIM WS-1220</p> 	<p>OUTSIDE CORNER WS-1221</p> 	<p>INSIDE CORNER WS-1222</p> 	<p>BASE TRIM WS-1223</p> 



Western States Metal Roofing

901 W. Watkins St.
Phoenix, AZ 85007
www.westernstatesmetalroofing.com

Phone: (602) 495-0048
Fax: (602) 261-7726
877-PURLINS (787-5467)



STANDARD TRIMS

PANEL TYPE:
BOARD AND BATTEN

A	07-18-2023
REV:	DATE:
DETAIL #: WP-WSD-ST2	

BASE WS-1224	TRIM CLEAT WS-1225		



Western States Metal Roofing

901 W. Watkins St.
Phoenix, AZ 85007

www.westernstatesmetalroofing.com

Phone: (602) 495-0048

Fax: (602) 261-7726

877-PURLINS (787-5467)



STANDARD TRIMS

PANEL TYPE:

BOARD AND BATTEN

A	07-18-2023
REV:	DATE:
DETAIL #:	
WP-WSD-ST3	

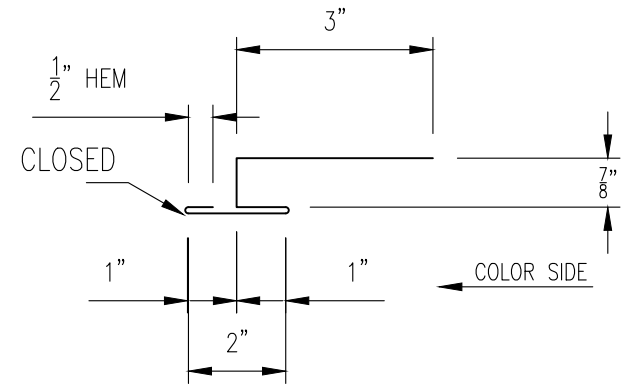
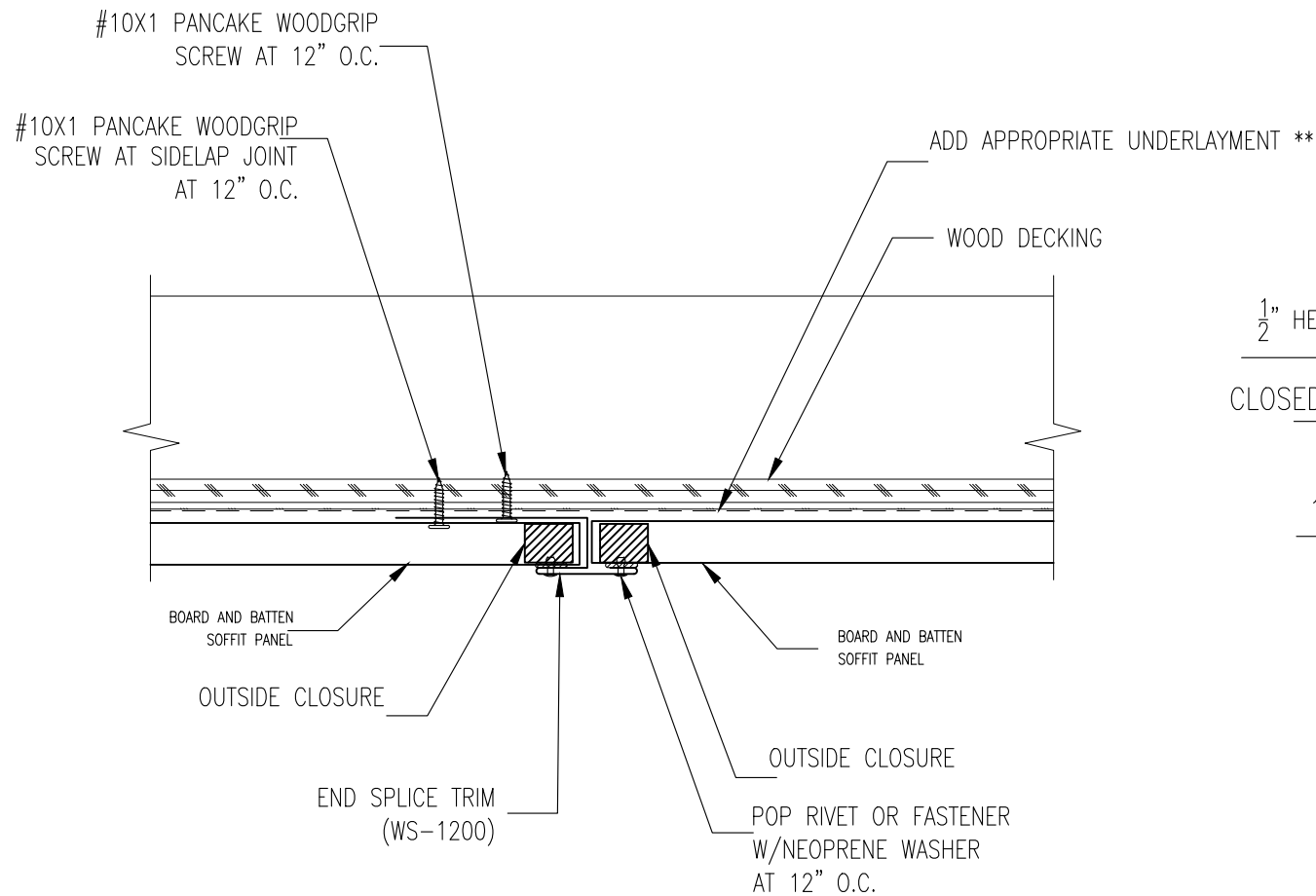

END SPLICE TRIM
(WS-1200)

**WSMR RECOMMENDS SHARKSKIN ®
ULTRA OR SHARKSKIN ® ULTRASA

GAUGE: _____	COLOR: _____
LENGTH: _____	FINISH: _____
MATERIAL: _____	

SOFFIT END SPLICE DETAIL		
	A	7-18-2023
PANEL TYPE: BOARD AND BATTEN	REV:	DATE:
	DETAIL #: WP-WSD-W1	



Western States Metal Roofing

901 W. Watkins St.
Phoenix, AZ 85007
www.westernstatesmetalroofing.com

Phone: (602) 495-0048
Fax: (602) 261-7726
877-PURLINS (787-5467)



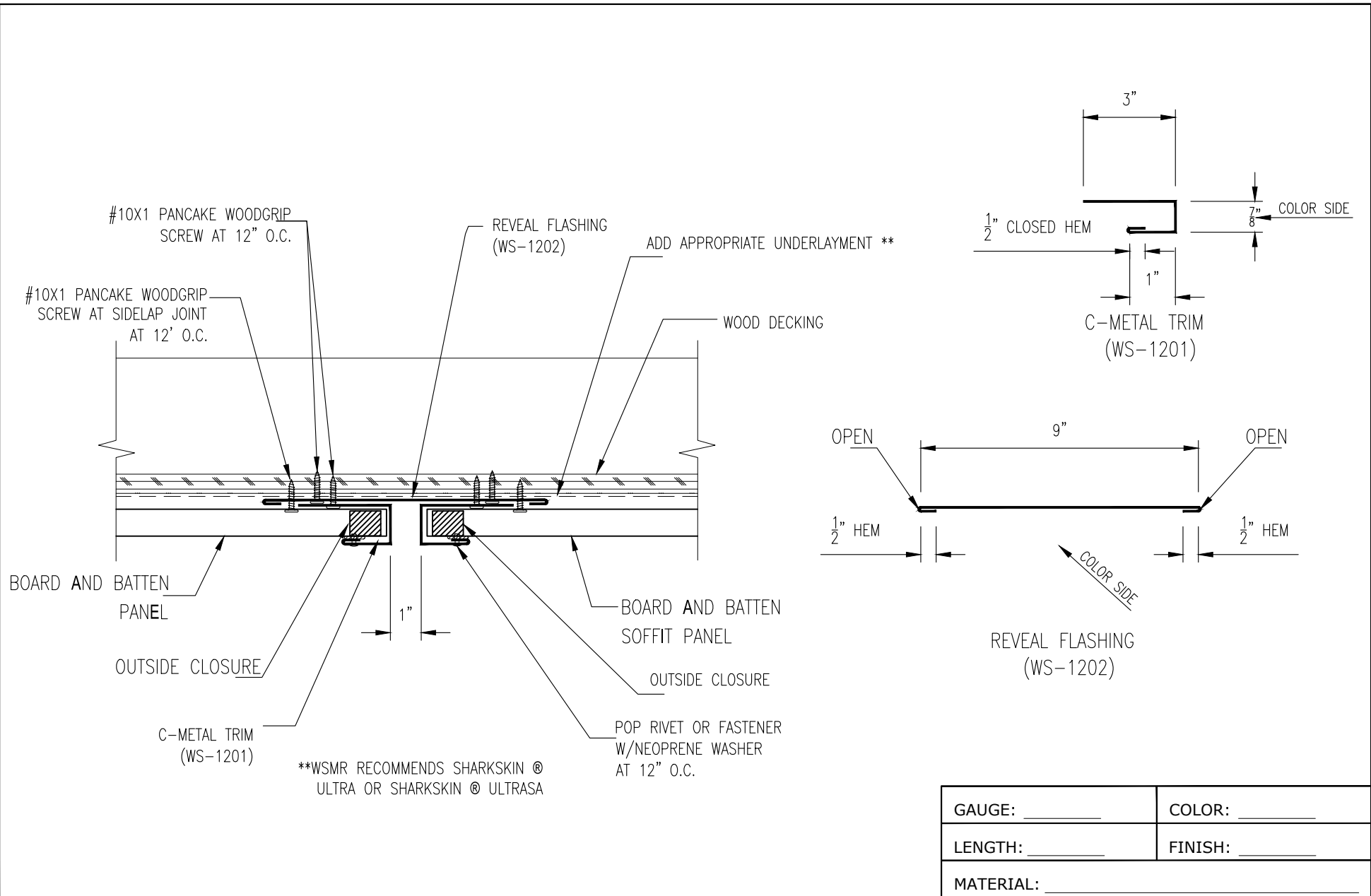

GUAGE: _____	COLOR: _____
LENGTH: _____	FINISH: _____
MATERIAL: _____	

WALL/SOFFIT END SPLICE DETAIL	A	7-18-2023
	REV:	DATE:
PANEL TYPE: BOARD AND BATTEN	DETAIL #: WP-WSD-W2	



Western States Metal Roofing

901 W. Watkins St.
Phoenix, AZ 85007
www.westernstatesmetalroofing.com

Phone: (602) 495-0048
Fax: (602) 261-7726
877-PURLINS (787-5467)



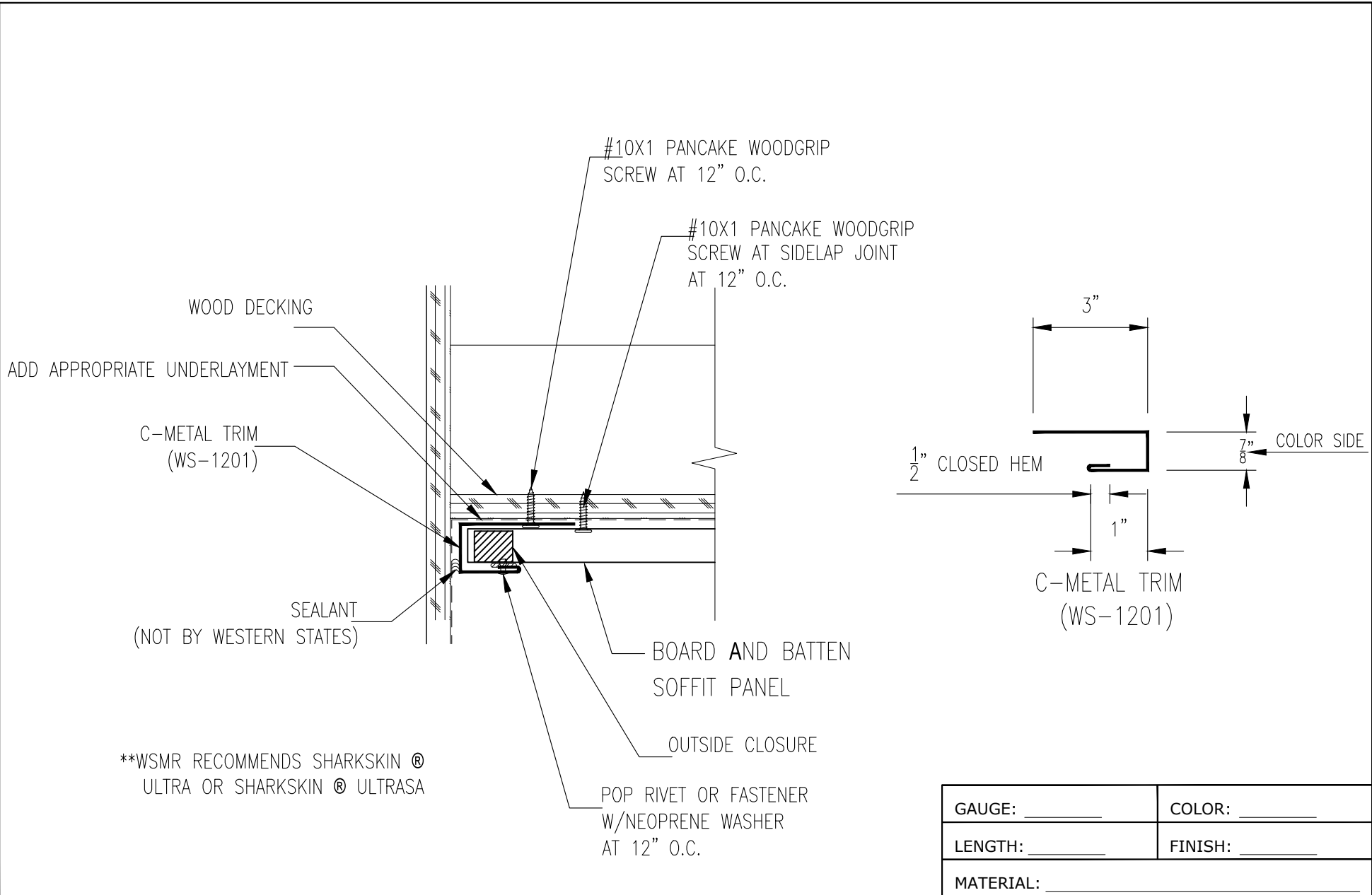

GUAGE: _____	COLOR: _____
LENGTH: _____	FINISH: _____
MATERIAL: _____	

SOFFIT END WALL DETAIL		
	A	7-18-2023
PANEL TYPE: BOARD AND BATTEN	REV:	DATE:
	DETAIL #:	WP-WSD-W3



Western States Metal Roofing

901 W. Watkins St.
Phoenix, AZ 85007
www.westernstatesmetalroofing.com

Phone: (602) 495-0048
Fax: (602) 261-7726
877-PURLINS (787-5467)



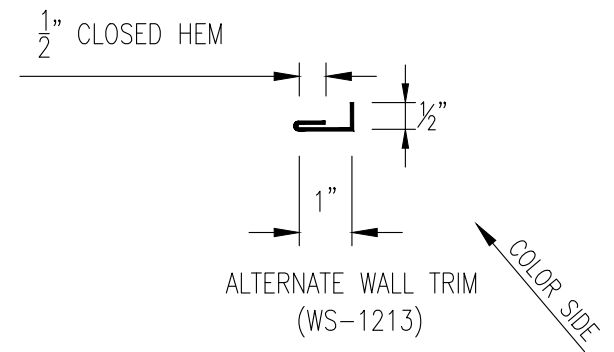
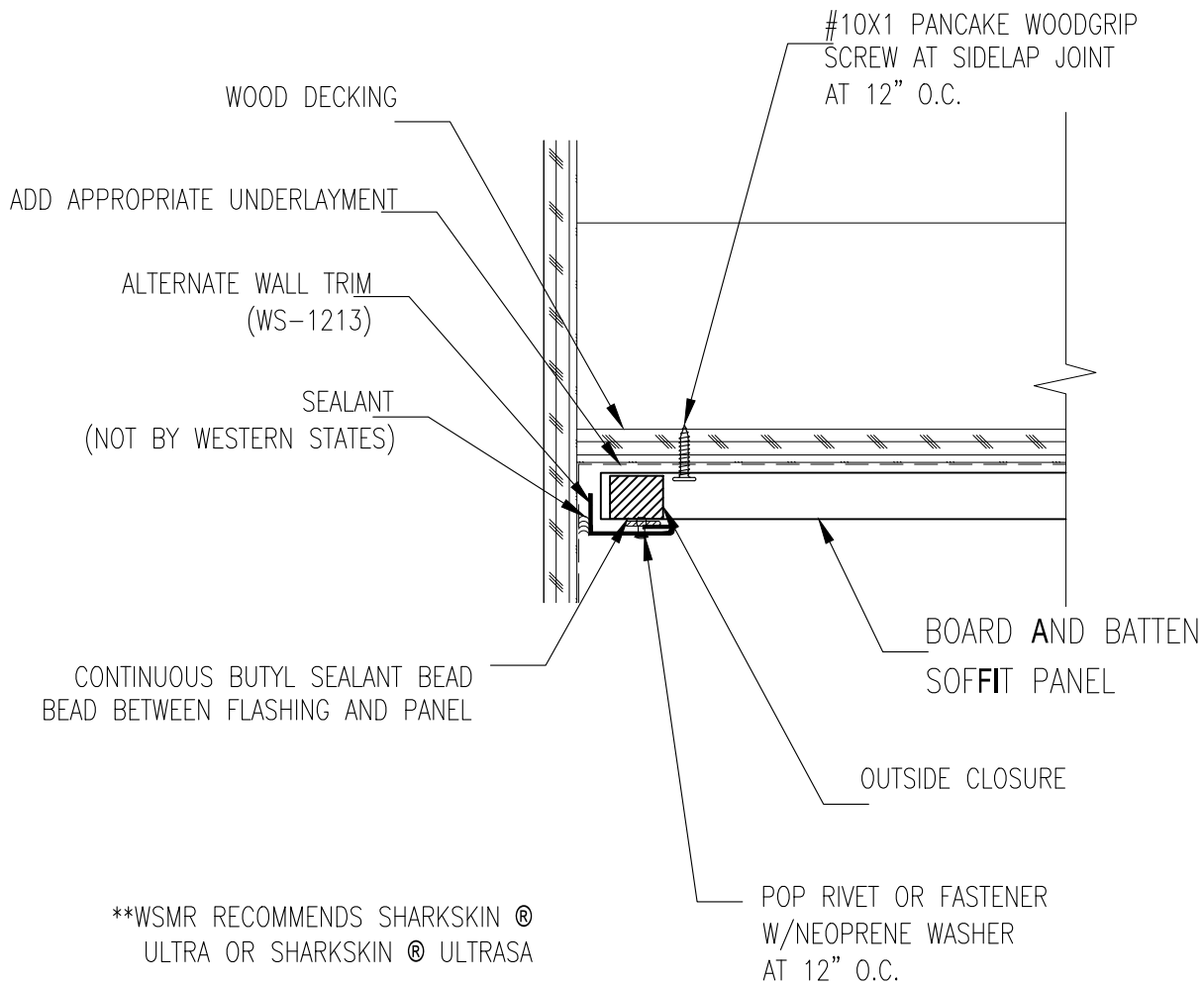

**WSMR RECOMMENDS SHARKSKIN® ULTRA OR SHARKSKIN® ULTRASA

GUAGE: _____	COLOR: _____
LENGTH: _____	FINISH: _____
MATERIAL: _____	

ALTERNATE SOFFIT END WALL DETAIL		
	A	7-18-2023
PANEL TYPE: BOARD AND BATTEN	REV:	DATE:
	DETAIL #: WP-WSD-W4	



Western States Metal Roofing

901 W. Watkins St.
Phoenix, AZ 85007
www.westernstatesmetalroofing.com

Phone: (602) 495-0048
Fax: (602) 261-7726
877-PURLINS (787-5467)



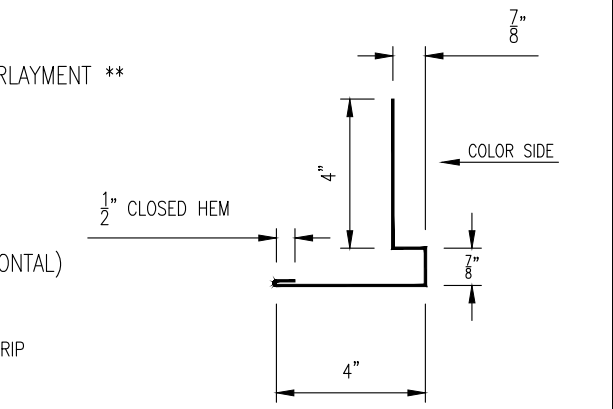
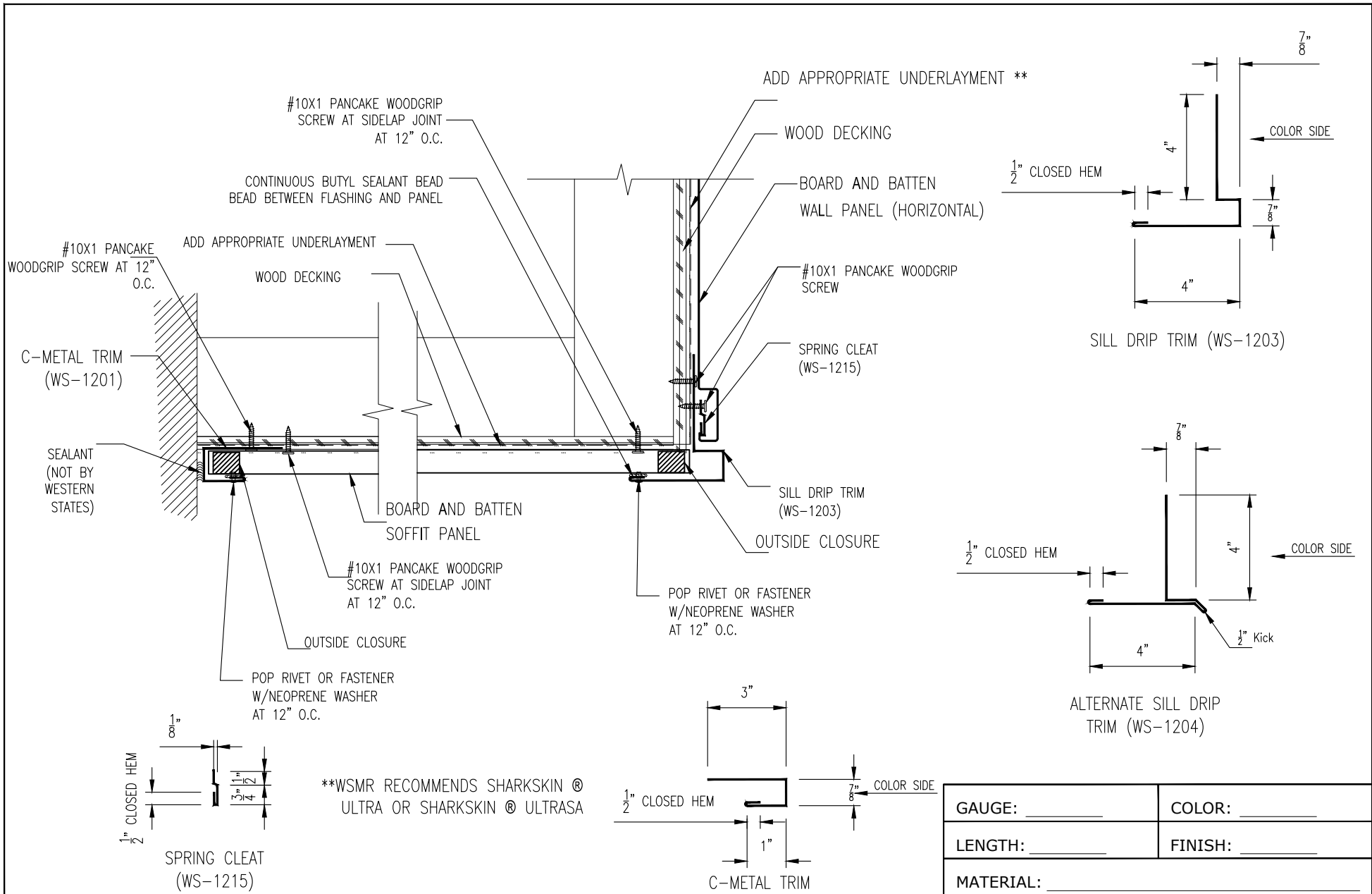

SILL DRIP TRIM (WS-1203)

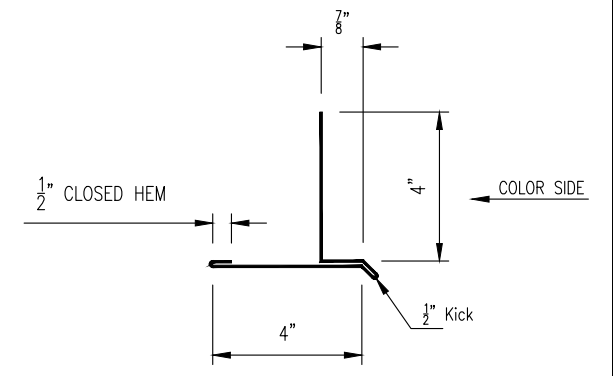

ALTERNATE SILL DRIP TRIM (WS-1204)

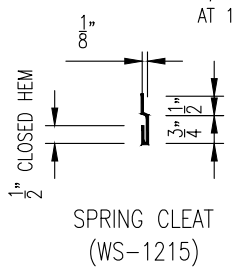

SPRING CLEAT (WS-1215)

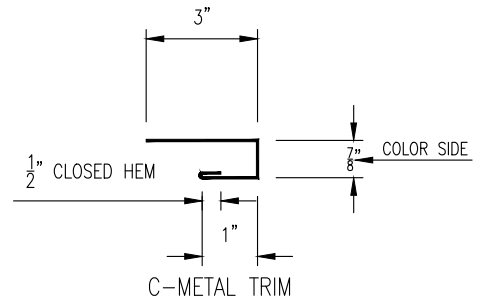

C-METAL TRIM

**WSMR RECOMMENDS SHARKSKIN @ ULTRA OR SHARKSKIN @ ULTRASA

GUAGE: _____	COLOR: _____
LENGTH: _____	FINISH: _____
MATERIAL: _____	



Western States Metal Roofing

901 W. Watkins St.
Phoenix, AZ 85007
www.westernstatesmetalroofing.com

Phone: (602) 495-0048
Fax: (602) 261-7726
877-PURLINS (787-5467)



SOFFIT TO WALL DRIP DETAIL Op 1			
		A	7-18-2023
PANEL TYPE: BOARD AND BATTEN		REV:	DATE:
		DETAIL #: WP-WSD-W5	

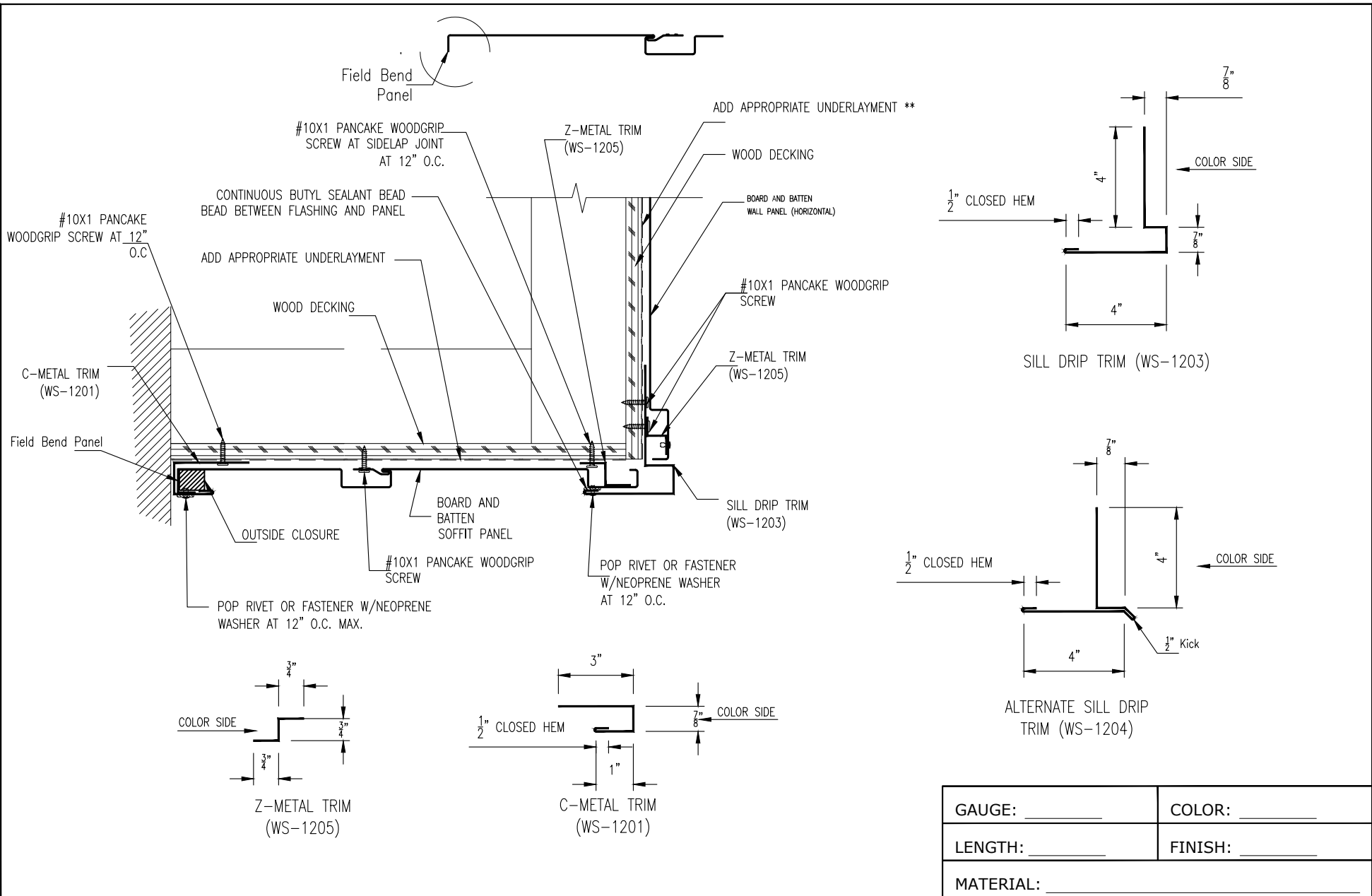

GUAGE: _____	COLOR: _____
LENGTH: _____	FINISH: _____
MATERIAL: _____	

SOFFIT TO WALL DRIP DETAIL Op. 2			
		A	7-18-2023
PANEL TYPE: BOARD AND BATTEN		REV:	DATE:
		DETAIL #: WP-WSD-W6	



Western States Metal Roofing

901 W. Watkins St.
Phoenix, AZ 85007
www.westernstatesmetalroofing.com

Phone: (602) 495-0048
Fax: (602) 261-7726
877-PURLINS (787-5467)



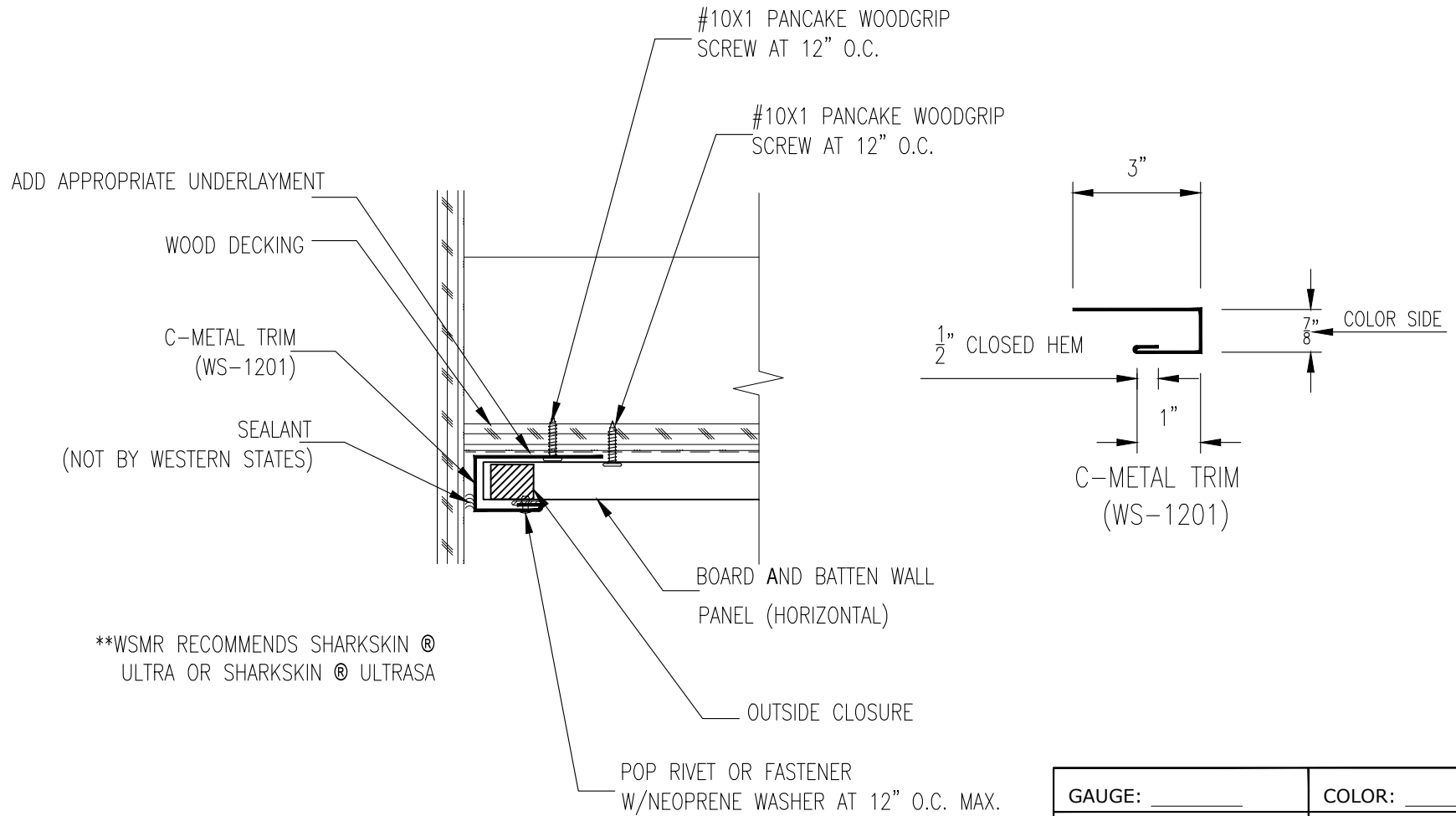

**WSMR RECOMMENDS SHARKSKIN ® ULTRA OR SHARKSKIN ® ULTRASA

GAUGE: _____	COLOR: _____
LENGTH: _____	FINISH: _____
MATERIAL: _____	

HORIZONTAL SIDING END WALL DETAIL		
	A	7-18-2023
PANEL TYPE: BOARD AND BATTEN	REV:	DATE:
	DETAIL #: WP-WSD-W7	



Western States Metal Roofing

901 W. Watkins St.
Phoenix, AZ 85007
www.westernstatesmetalroofing.com

Phone: (602) 495-0048
Fax: (602) 261-7726
877-PURLINS (787-5467)



REMOVE TAB

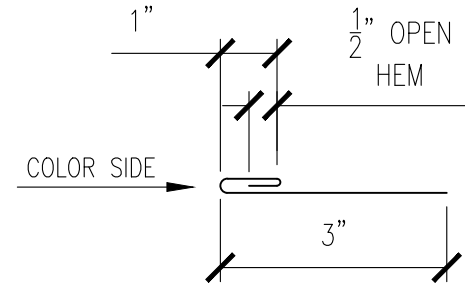
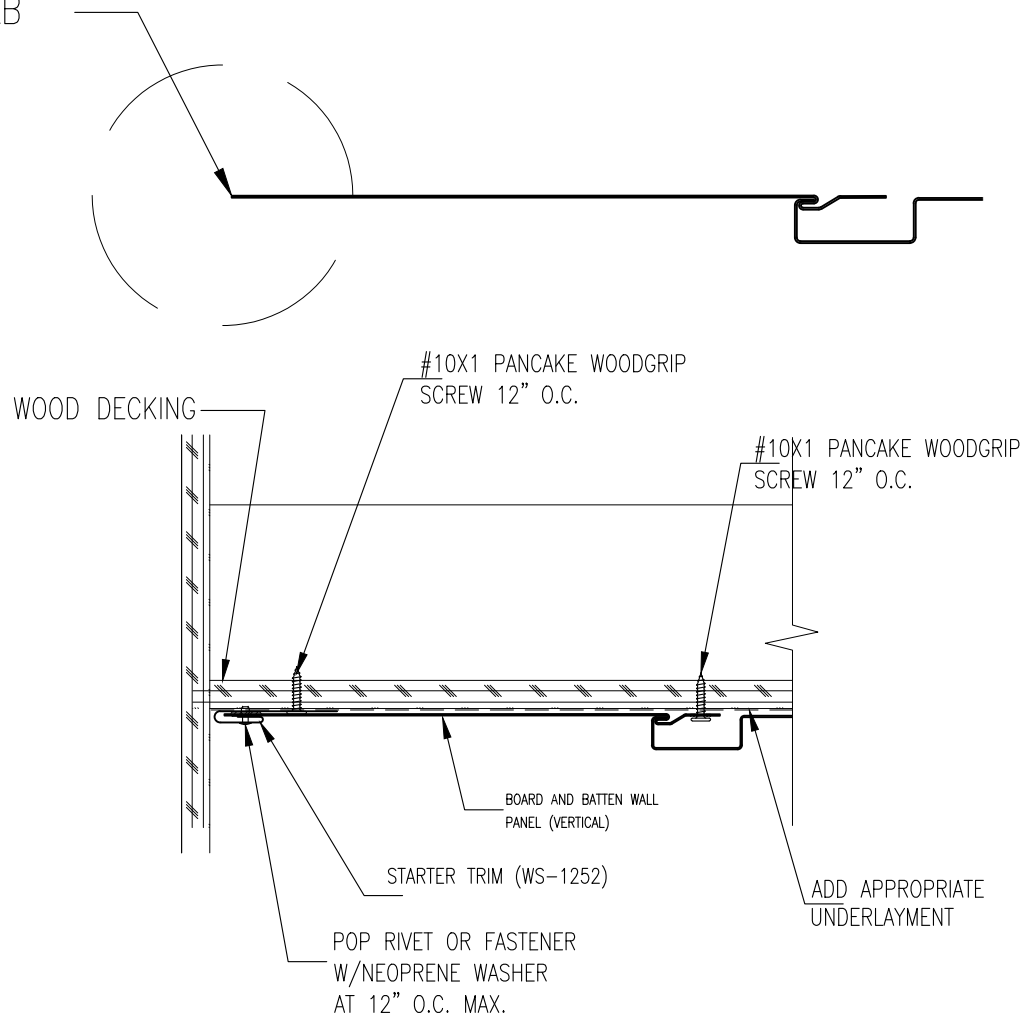

GABLE STARTER TRIM (WS-1218)

**WSMR RECOMMENDS SHARKSKIN ®
ULTRA OR SHARKSKIN ® ULTRASA

GAUGE: _____	COLOR: _____
LENGTH: _____	FINISH: _____
MATERIAL: _____	

VERTICAL SIDING END WALL DETAIL OP 1		
	A	7-18-2023
PANEL TYPE: BOARD AND BATTEN	REV:	DATE:
	DETAIL #: WP-WSD-W8	



Western States Metal Roofing

901 W. Watkins St.
Phoenix, AZ 85007
www.westernstatesmetalroofing.com

Phone: (602) 495-0048
Fax: (602) 261-7726
877-PURLINS (787-5467)



REMOVE TAB

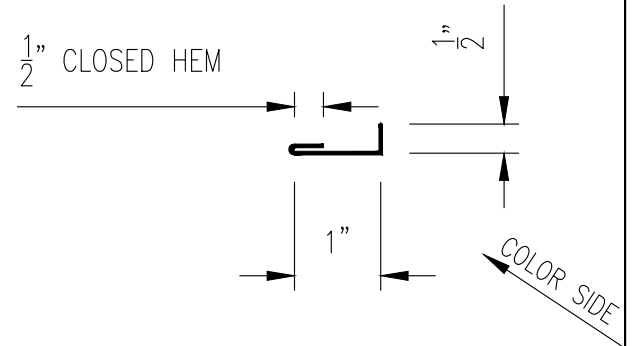
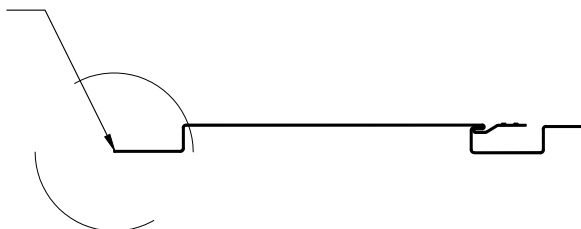

ALTERNATE WALL TRIM (WS-1213)

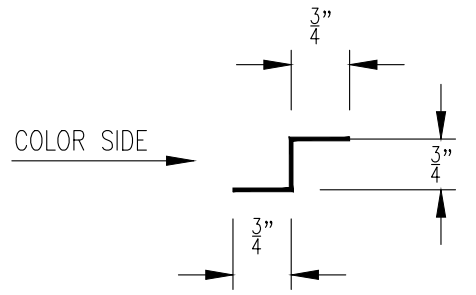
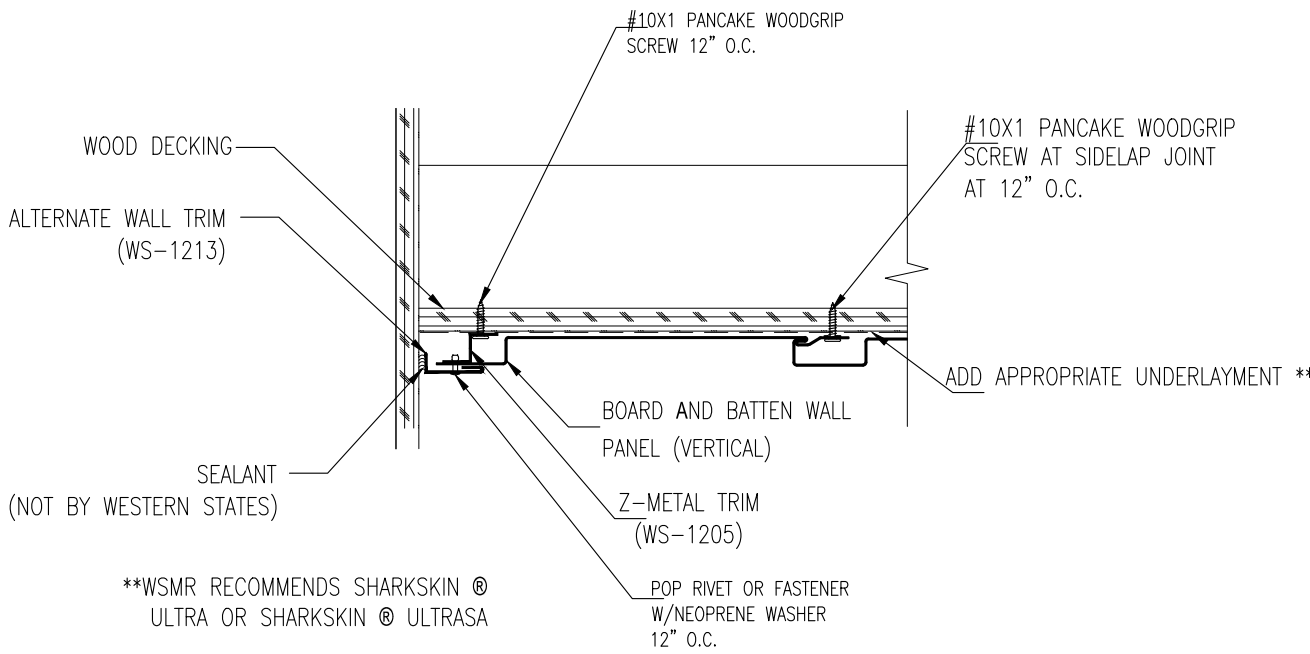

Z-METAL TRIM (WS-1205)

**WSMR RECOMMENDS SHARKSKIN ® ULTRA OR SHARKSKIN ® ULTRASA

GUAGE: _____	COLOR: _____
LENGTH: _____	FINISH: _____
MATERIAL: _____	



Western States Metal Roofing

901 W. Watkins St.
Phoenix, AZ 85007
www.westernstatesmetalroofing.com

Phone: (602) 495-0048
Fax: (602) 261-7726
877-PURLINS (787-5467)



VERTICAL SIDING END WALL DETAIL OP 2		
	A	7-18-2023
PANEL TYPE: BOARD AND BATTEN	REV:	DATE:
	DETAIL #: WP-WSD-W9	

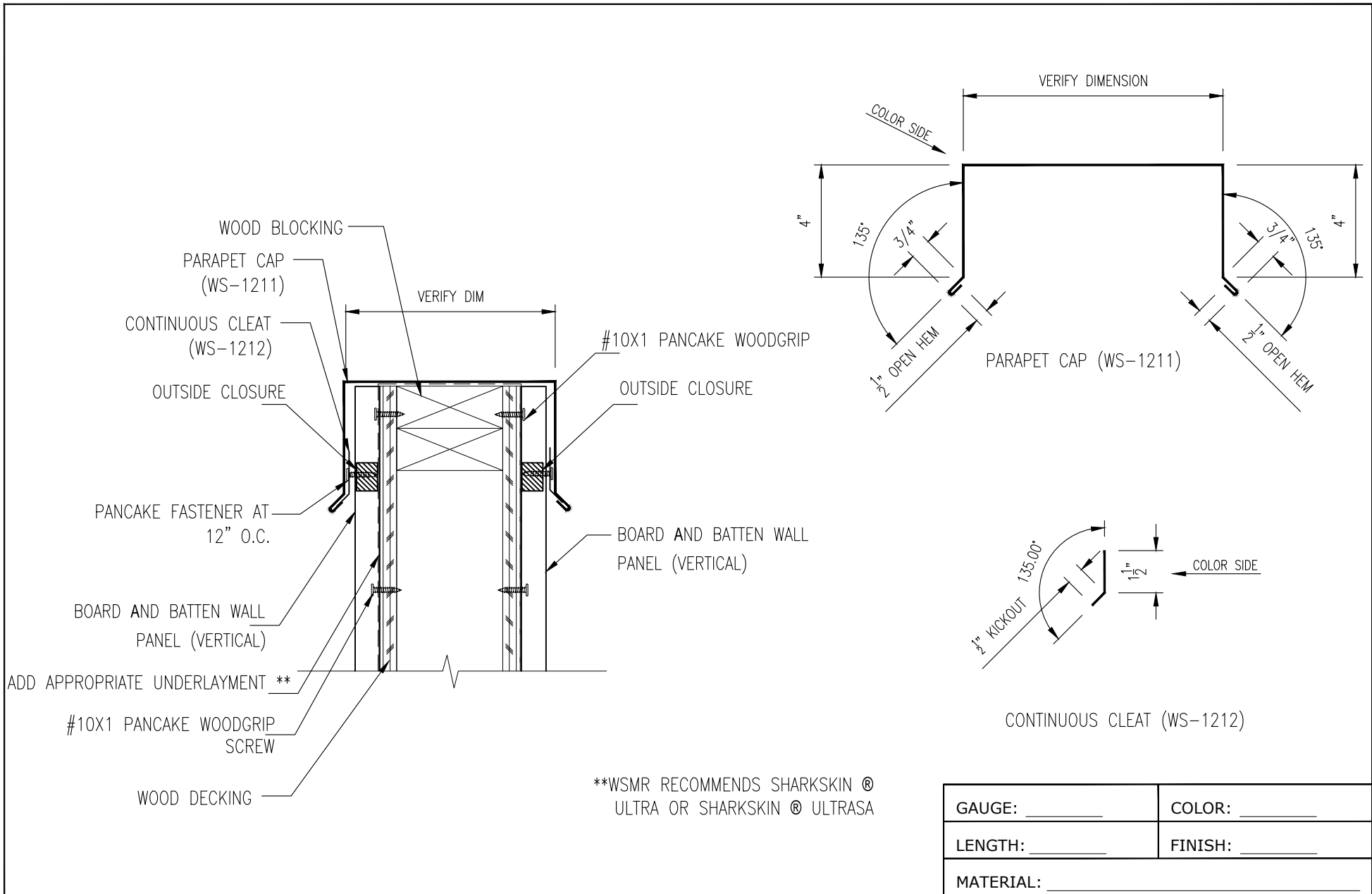

**WSMR RECOMMENDS SHARKSKIN ® ULTRA OR SHARKSKIN ® ULTRASA

GUAGE: _____	COLOR: _____
LENGTH: _____	FINISH: _____
MATERIAL: _____	

PARAPET WALL DETAIL			
PANEL TYPE: BOARD AND BATTEN		A	7-18-2023
		REV:	DATE:
		DETAIL #: WP-WSD-W10	



Western States Metal Roofing

901 W. Watkins St.
Phoenix, AZ 85007
www.westernstatesmetalroofing.com

Phone: (602) 495-0048
Fax: (602) 261-7726
877-PURLINS (787-5467)



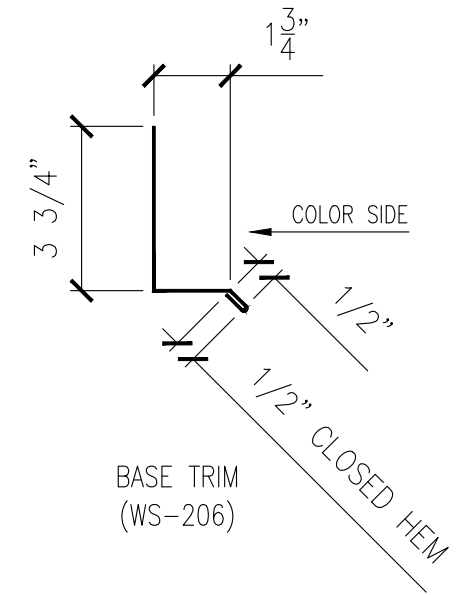
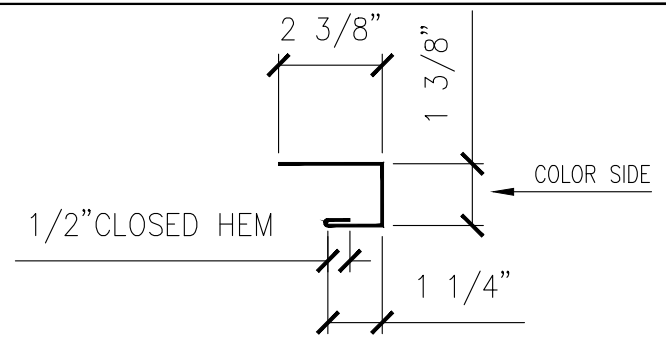
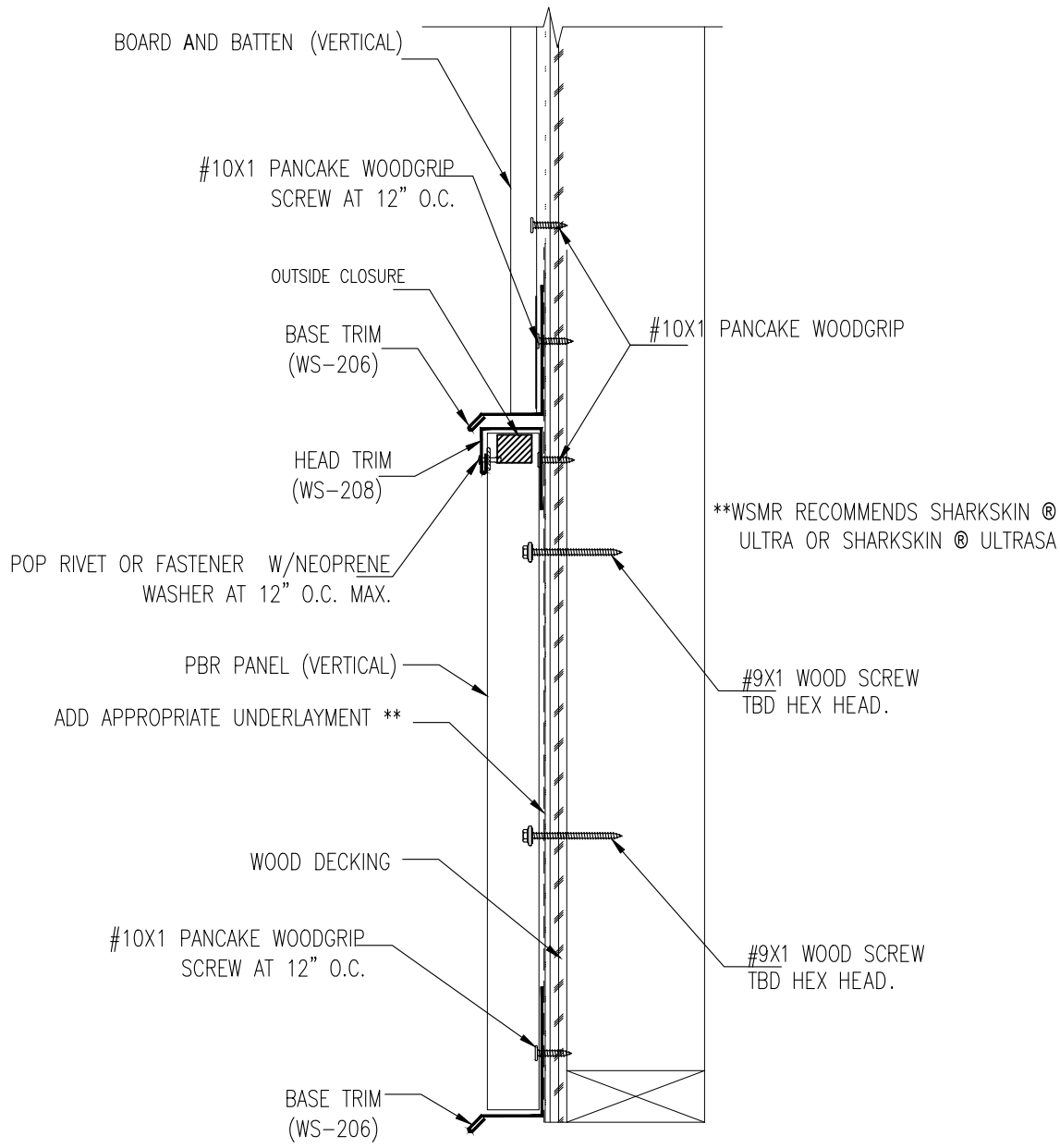

GAUGE: _____	COLOR: _____						
LENGTH: _____	FINISH: _____						
MATERIAL: _____							
ALTERNATE WAINSCOT TRANSITION DETAIL (BB-12 TO R-PANEL) VERTICAL							
PANEL TYPE: BOARD AND BATTEN	<table border="1"> <tr> <td>A</td> <td>7-18-2023</td> </tr> <tr> <td>REV:</td> <td>DATE:</td> </tr> <tr> <td colspan="2">DETAIL #: WP-WSD-W11</td> </tr> </table>	A	7-18-2023	REV:	DATE:	DETAIL #: WP-WSD-W11	
A	7-18-2023						
REV:	DATE:						
DETAIL #: WP-WSD-W11							



Western States Metal Roofing

901 W. Watkins St.
Phoenix, AZ 85007
www.westernstatesmetalroofing.com

Phone: (602) 495-0048
Fax: (602) 261-7726
877-PURLINS (787-5467)



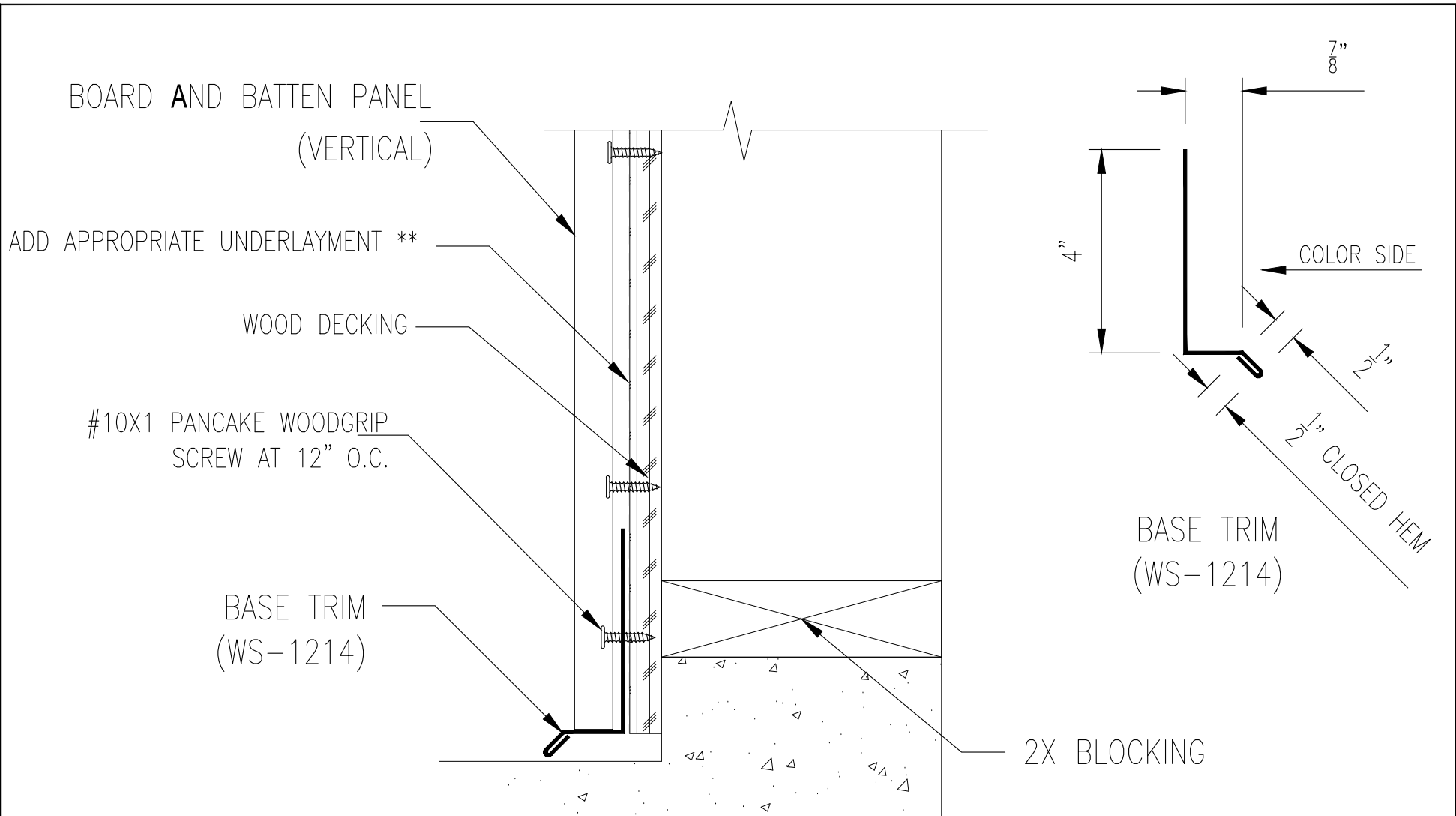

**WSMR RECOMMENDS SHARKSKIN ®
ULTRA OR SHARKSKIN ® ULTRASA

GAUGE: _____	COLOR: _____
LENGTH: _____	FINISH: _____
MATERIAL: _____	

BASE DETAIL VERTICAL		
	A	7-18-2023
PANEL TYPE: BOARD AND BATTEN	REV:	DATE:
	DETAIL #: WP-WSD-W12	



Western States Metal Roofing

901 W. Watkins St.
Phoenix, AZ 85007
www.westernstatesmetalroofing.com

Phone: (602) 495-0048
Fax: (602) 261-7726
877-PURLINS (787-5467)



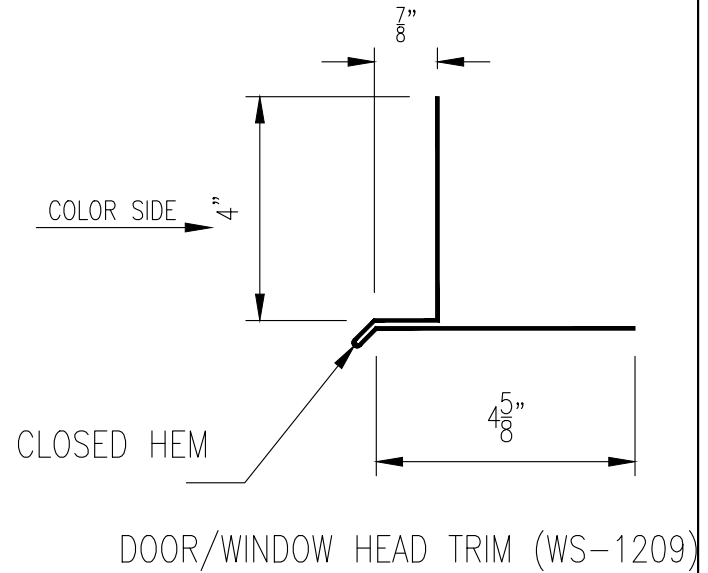
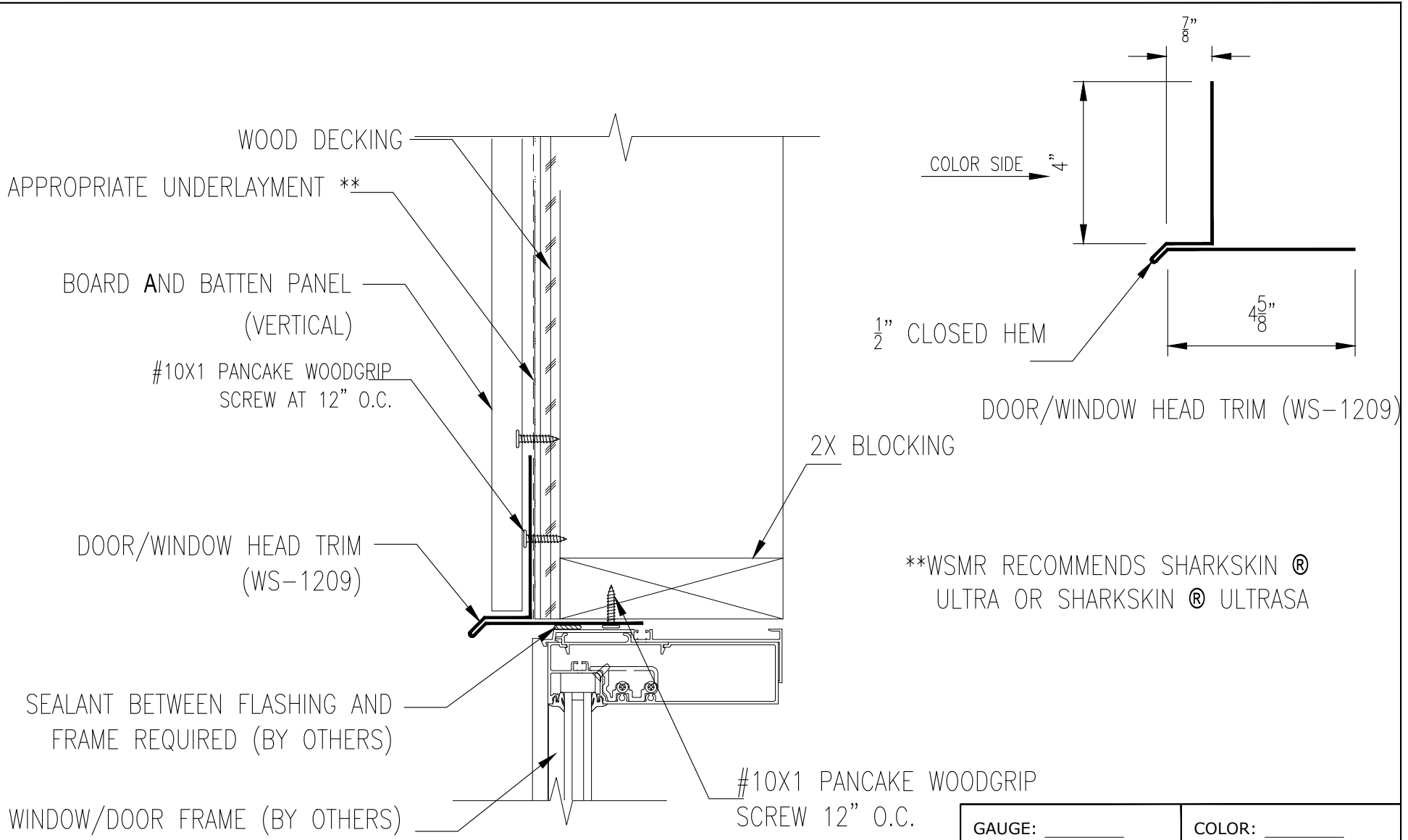

**WSMR RECOMMENDS SHARKSKIN®
ULTRA OR SHARKSKIN® ULTRASA

GAUGE: _____	COLOR: _____
LENGTH: _____	FINISH: _____
MATERIAL: _____	

DOOR / WINDOW HEAD DETAIL VERTICAL		
	A	7-18-2023
PANEL TYPE: BOARD AND BATTEN	REV:	DATE:
	DETAIL #: WP-WSD-W13	



Western States Metal Roofing

901 W. Watkins St.
Phoenix, AZ 85007
www.westernstatesmetalroofing.com

Phone: (602) 495-0048
Fax: (602) 261-7726
877-PURLINS (787-5467)



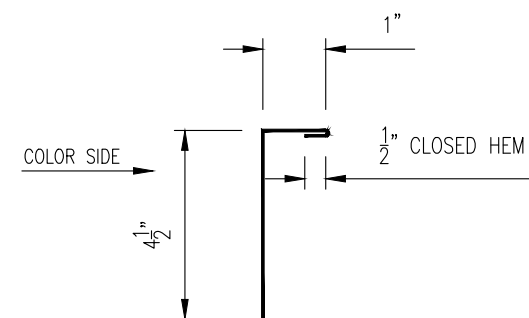
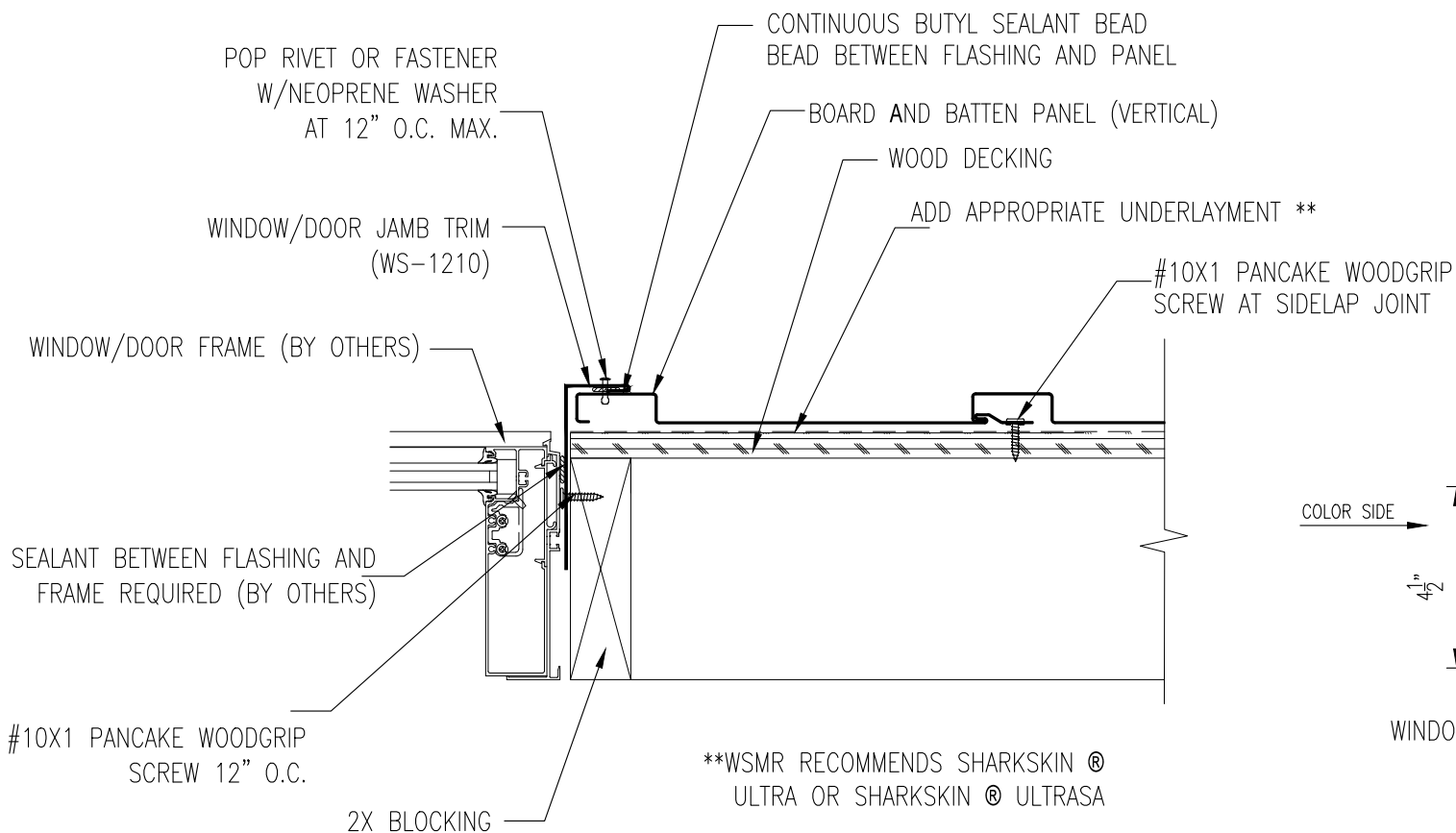

WINDOW/DOOR JAMB TRIM (WS-1210)

GUAGE: _____	COLOR: _____
LENGTH: _____	FINISH: _____
MATERIAL: _____	

WINDOW / DOOR JAMB DETAIL OP 1		
	A	7-18-2023
PANEL TYPE: BOARD AND BATTEN	REV:	DATE:
	DETAIL #: WP-WSD-W14	



Western States Metal Roofing

901 W. Watkins St.
Phoenix, AZ 85007
www.westernstatesmetalroofing.com

Phone: (602) 495-0048
Fax: (602) 261-7726
877-PURLINS (787-5467)



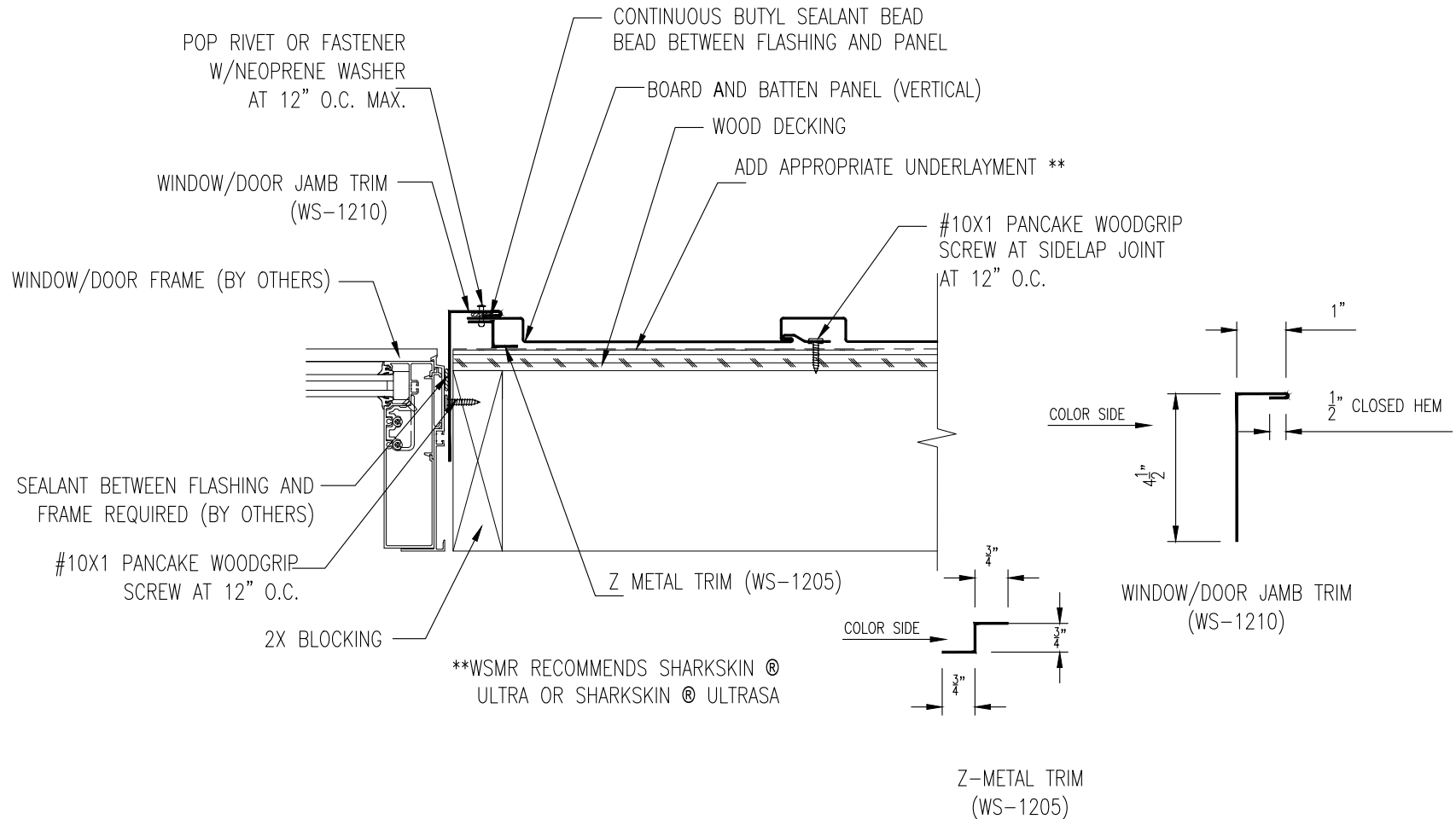

GAUGE: _____	COLOR: _____
LENGTH: _____	FINISH: _____
MATERIAL: _____	

WINDOW / DOOR JAMB DETAIL OP 2		
	A	7-18-2023
PANEL TYPE: BOARD AND BATTEN	REV:	DATE:
	DETAIL #: WP-WSD-W15	



Western States Metal Roofing

901 W. Watkins St.
Phoenix, AZ 85007
www.westernstatesmetalroofing.com

Phone: (602) 495-0048
Fax: (602) 261-7726
877-PURLINS (787-5467)



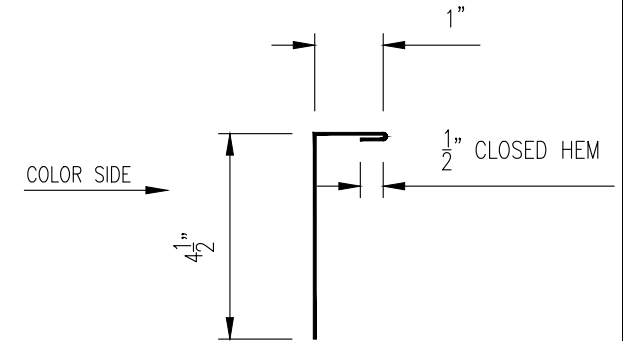
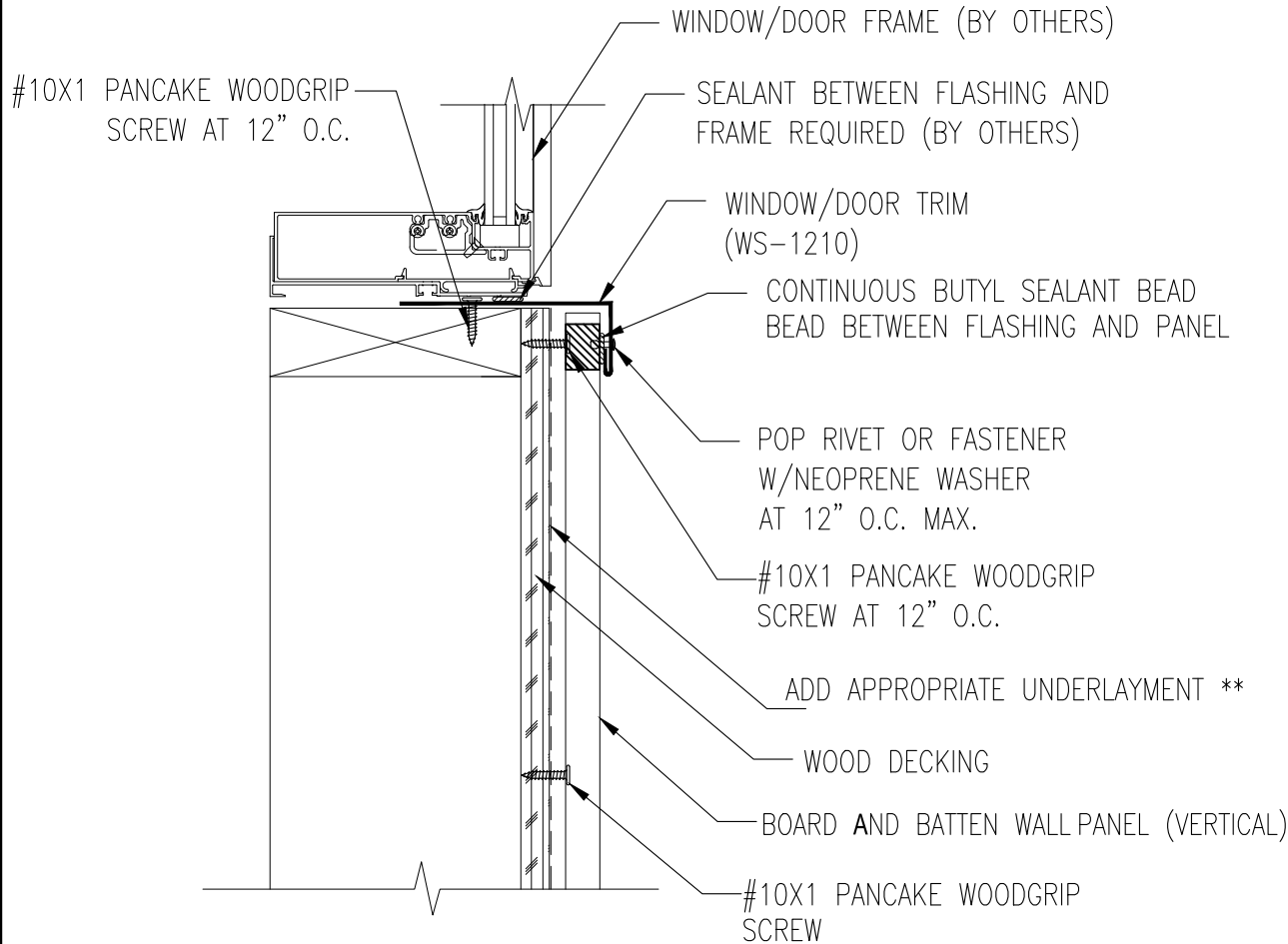

WINDOW/DOOR TRIM (WS-1210)

**WSMR RECOMMENDS SHARKSKIN® ULTRA OR SHARKSKIN® ULTRASA

GAUGE: _____	COLOR: _____
LENGTH: _____	FINISH: _____
MATERIAL: _____	

DOOR / WINDOW SILL DETAIL VERTICAL		
	A	7-18-2023
PANEL TYPE: BOARD AND BATTEN	REV:	DATE:
	DETAIL #: WP-WSD-W16	



Western States Metal Roofing

901 W. Watkins St.
 Phoenix, AZ 85007
www.westernstatesmetalroofing.com

Phone: (602) 495-0048
 Fax: (602) 261-7726
 877-PURLINS (787-5467)



**WSMR RECOMMENDS SHARKSKIN®
ULTRA OR SHARKSKIN® ULTRASA

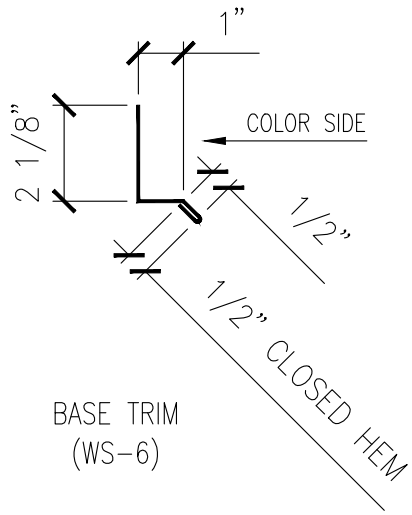
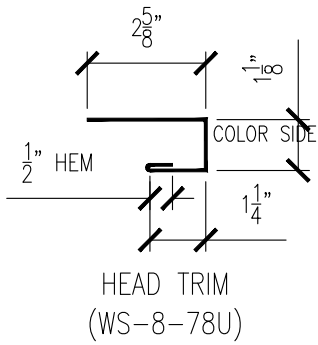
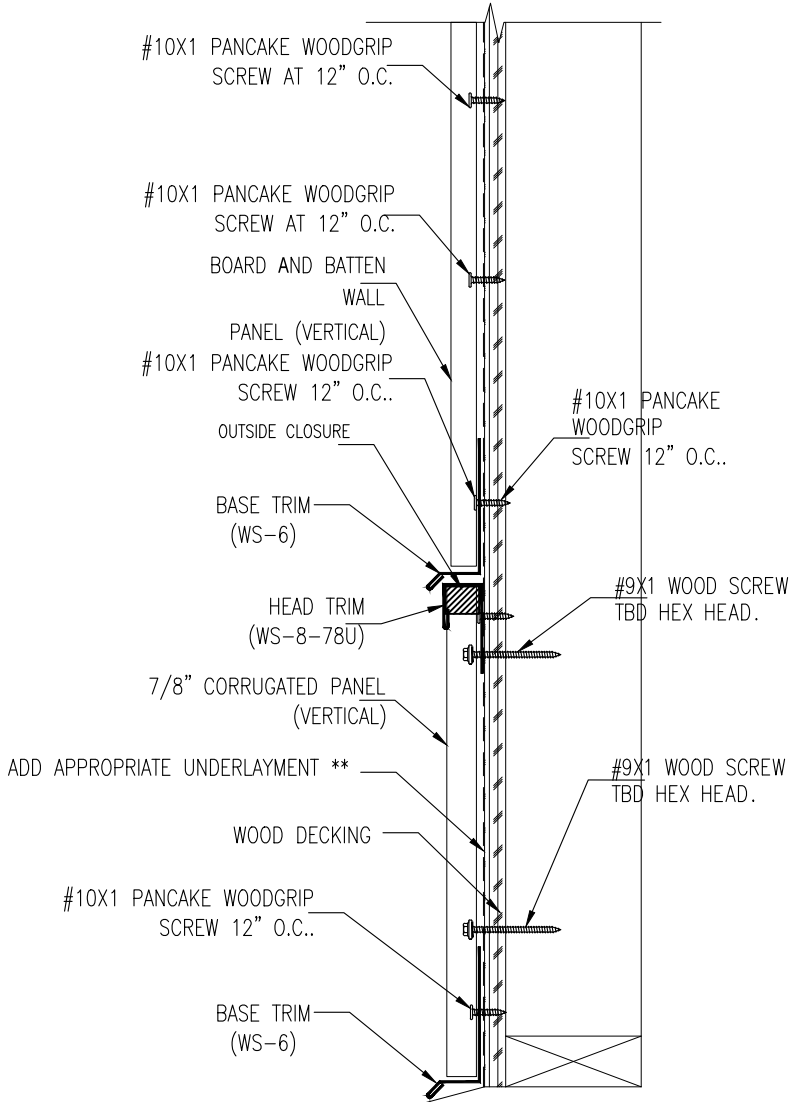

GUAGE: _____	COLOR: _____
LENGTH: _____	FINISH: _____
MATERIAL: _____	

ALTERNATE WAINSCOAT VERTICAL TRANSITION DETAIL (BOARD AND BATTEN TO 7/8" CORRUGATED PANEL)		
	A	7-18-2023
PANEL TYPE: BOARD AND BATTEN	REV:	DATE:
	DETAIL #: WP-WSD-W17	



Western States Metal Roofing

901 W. Watkins St.
Phoenix, AZ 85007
www.westernstatesmetalroofing.com

Phone: (602) 495-0048
Fax: (602) 261-7726
877-PURLINS (787-5467)



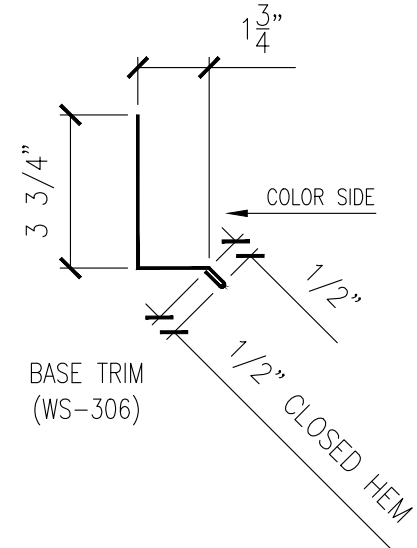
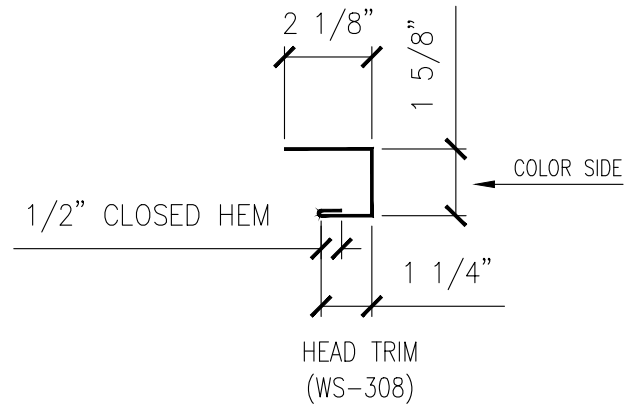
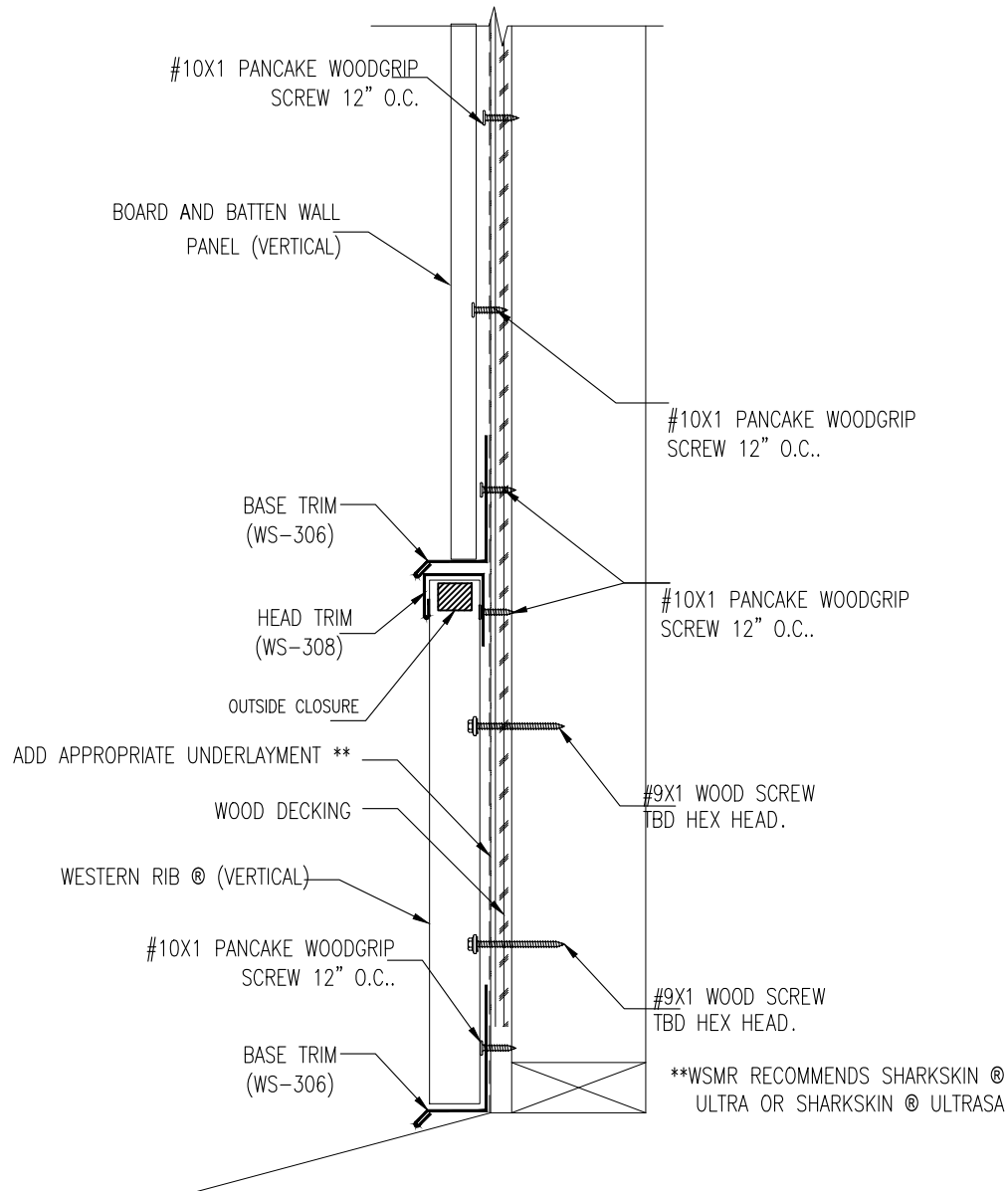

GUAGE: _____	COLOR: _____
LENGTH: _____	FINISH: _____
MATERIAL: _____	

ALTERNATE WAINSCOT TRANSITION DETAIL (BOARD AND BATTEN TO WESTERN RIB)		
	A	7-18-2023
PANEL TYPE: BOARD AND BATTEN	REV:	DATE:
	DETAIL #: WP-WSD-W18	

**WSMR RECOMMENDS SHARKSKIN ®
ULTRA OR SHARKSKIN ® ULTRASA



Western States Metal Roofing

901 W. Watkins St.
Phoenix, AZ 85007
www.westernstatesmetalroofing.com

Phone: (602) 495-0048
Fax: (602) 261-7726
877-PURLINS (787-5467)



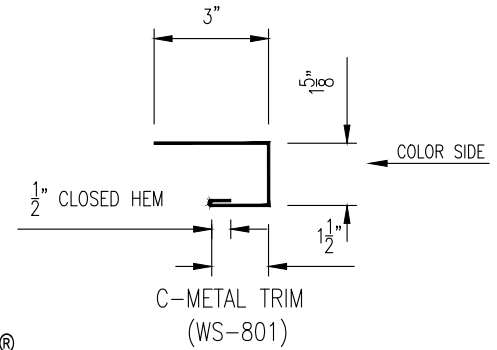
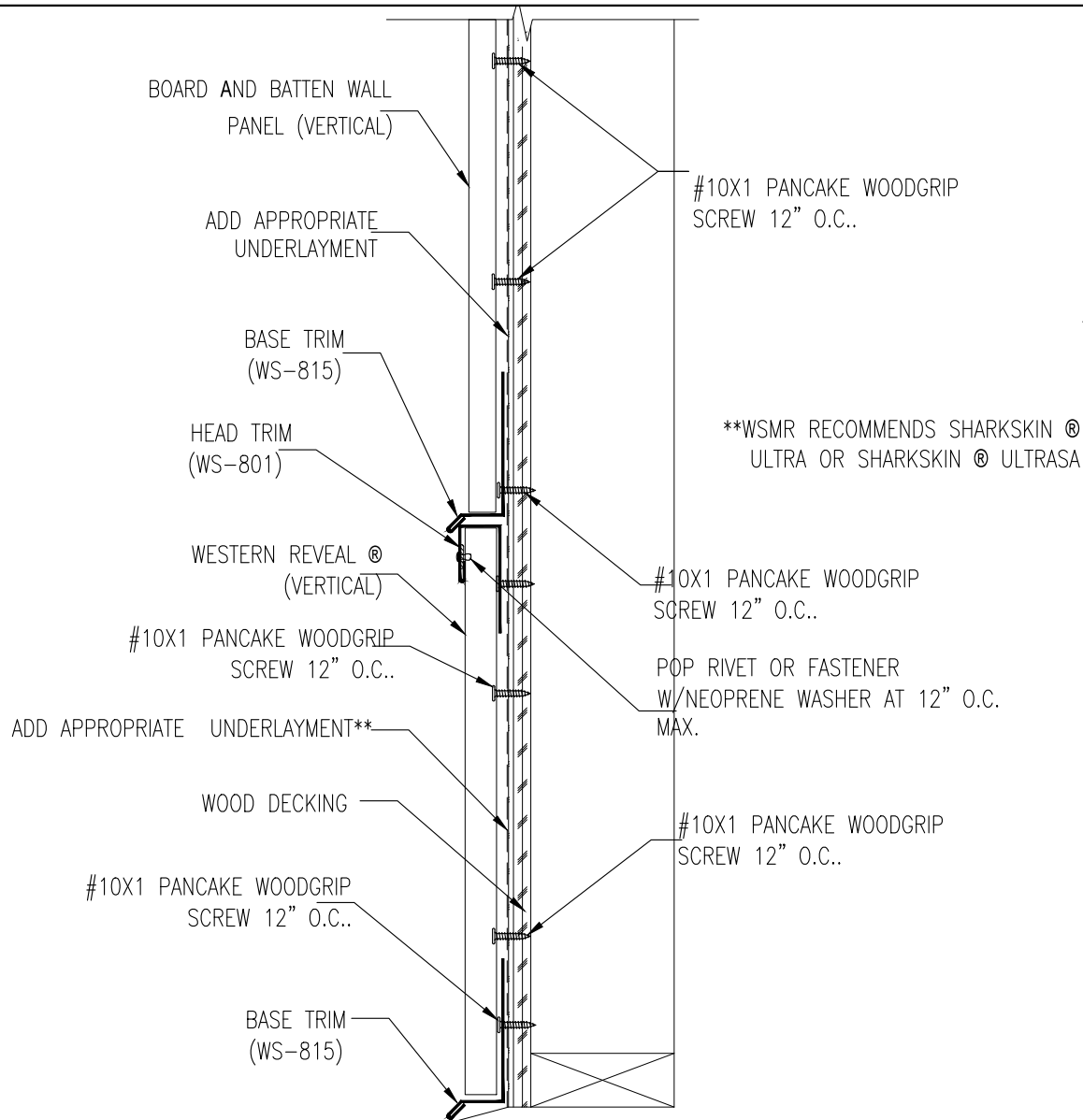

**WSMR RECOMMENDS SHARKSKIN ® ULTRA OR SHARKSKIN ® ULTRASA

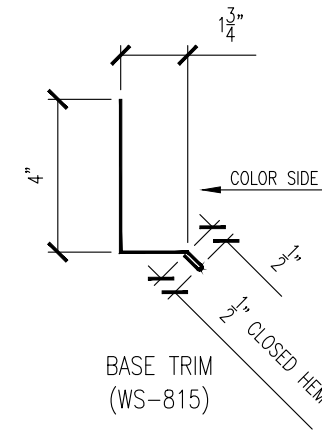

GUAGE: _____	COLOR: _____
LENGTH: _____	FINISH: _____
MATERIAL: _____	

WAINSCOAT TRANSITION DETAIL VERTICAL			
(BOARD AND BATTEN TO WESTERN REVEAL ® VERTICAL)		A	7-18-2023
REVISIONS		REV:	DATE:
PANEL TYPE: BOARD AND BATTEN		DETAIL #: WP-WSD-W19	



Western States Metal Roofing

901 W. Watkins St.
Phoenix, AZ 85007
www.westernstatesmetalroofing.com

Phone: (602) 495-0048
Fax: (602) 261-7726
877-PURLINS (787-5467)



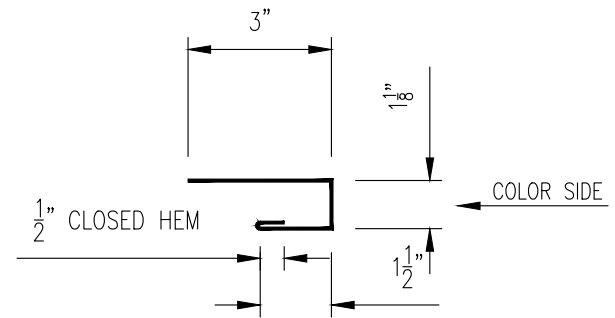
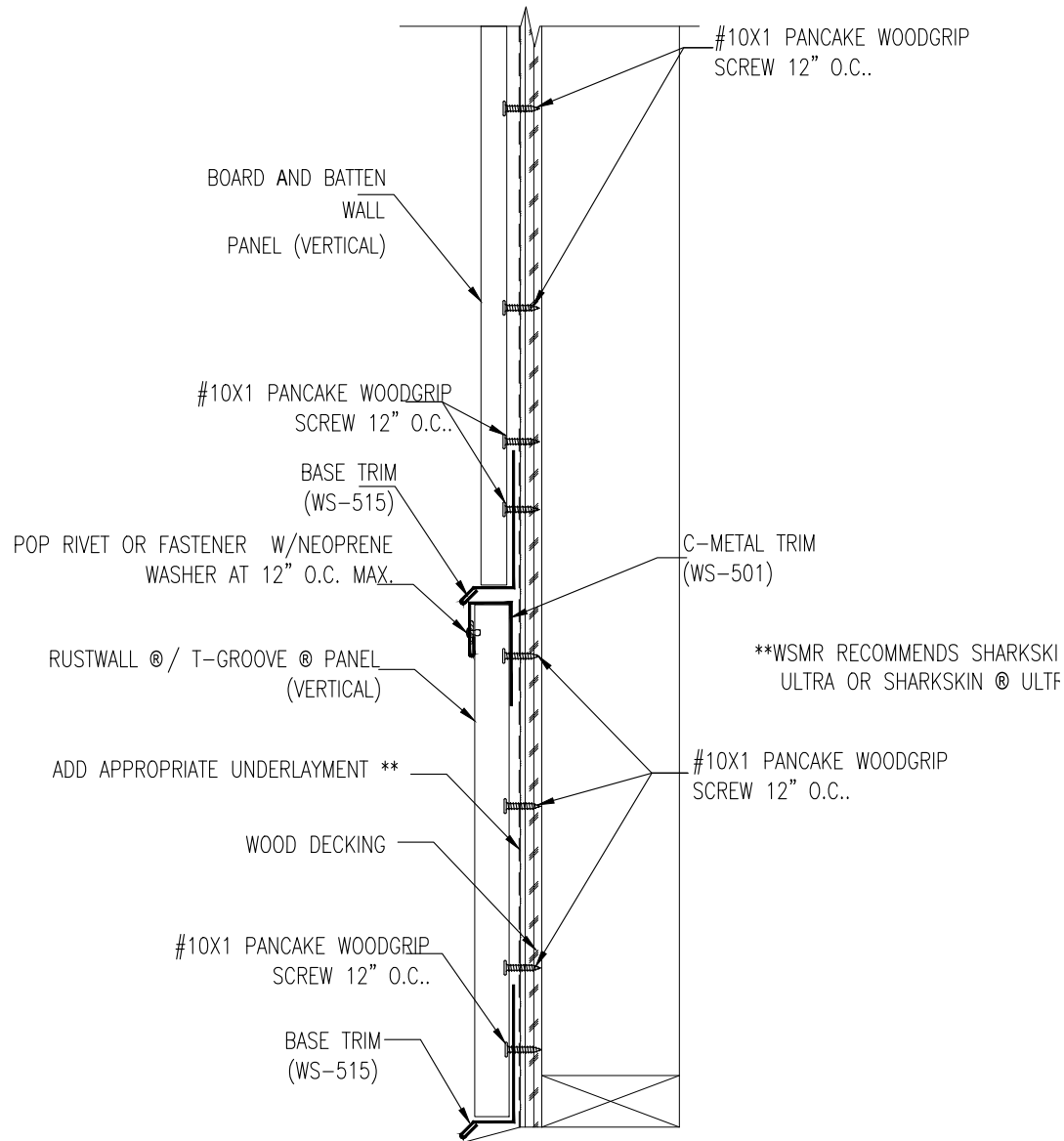

C-METAL TRIM (WS-501)

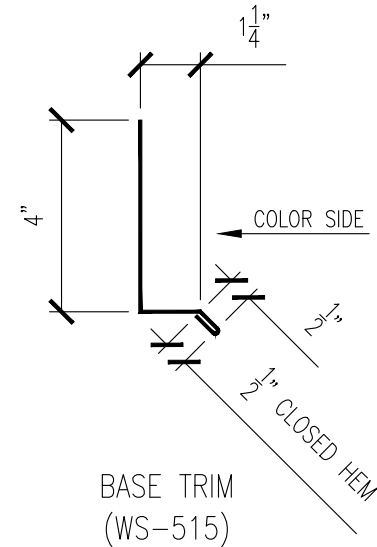

BASE TRIM (WS-515)

**WSMR RECOMMENDS SHARKSKI ULTRA OR SHARKSKIN ® ULTF

GUAGE: _____	COLOR: _____
LENGTH: _____	FINISH: _____
MATERIAL: _____	

WAINSCOAT TRANSITION DETAIL VERTICAL (BOARD AND BATTEN TO RUSTWALL ®)		
	A	7-18-2023
PANEL TYPE: BOARD AND BATTEN	REV:	DATE:
	DETAIL #: WP-WSD-W20	



Western States Metal Roofing

901 W. Watkins St.
Phoenix, AZ 85007
www.westernstatesmetalroofing.com

Phone: (602) 495-0048
Fax: (602) 261-7726
877-PURLINS (787-5467)



#10X1 PANCAKE WOODGRIP
SCREW AT 12" O.C.

BOARD AND BATTEN WALL
PANEL (VERTICAL)

BASE TRIM
(WS-614)

HEAD TRIM
(WS-601)

POP RIVET OR FASTENER W/NEOPRENE WASHER
AT 12" O.C. MAX.

ADD APPROPRIATE UNDERLAYMENT **

WOOD DECKING

WESTERN WAVE ®
(VERTICAL)

#10X1 PANCAKE WOODGRIP
SCREW AT 12" O.C.

BASE TRIM
(WS-614)

**WSMR RECOMMENDS SHARKSKIN ®
ULTRA OR SHARKSKIN ® ULTRASA

#10X1 PANCAKE WOODGRIP
SCREW AT 12" O.C.

#10X1 PANCAKE WOODGRIP
SCREW AT 12" O.C.

#10X1 PANCAKE WOODGRIP
SCREW AT 12" O.C.

#10X1 PANCAKE WOODGRIP
SCREW AT 12" O.C.

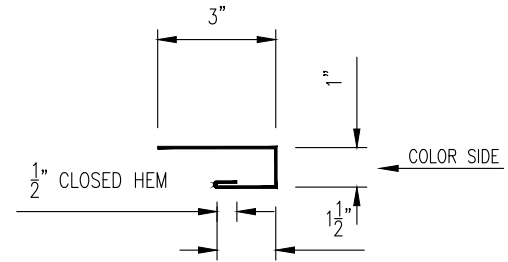

C-METAL TRIM
(WS-601)

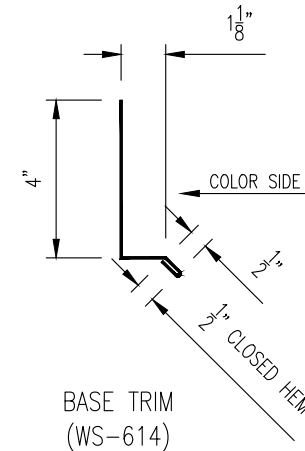

BASE TRIM
(WS-614)

GAUGE: _____	COLOR: _____
LENGTH: _____	FINISH: _____
MATERIAL: _____	

WAINSCOT TRANSITION DETAIL VERTICAL (BOARD AND BATTEN TO WESTERN WAVE ®)		
	A	7-18-2023
PANEL TYPE: BOARD AND BATTEN	REV:	DATE:
	DETAIL #: WP-WSD-W21	



Western States Metal Roofing

901 W. Watkins St.
Phoenix, AZ 85007
www.westernstatesmetalroofing.com

Phone: (602) 495-0048
Fax: (602) 261-7726
877-PURLINS (787-5467)



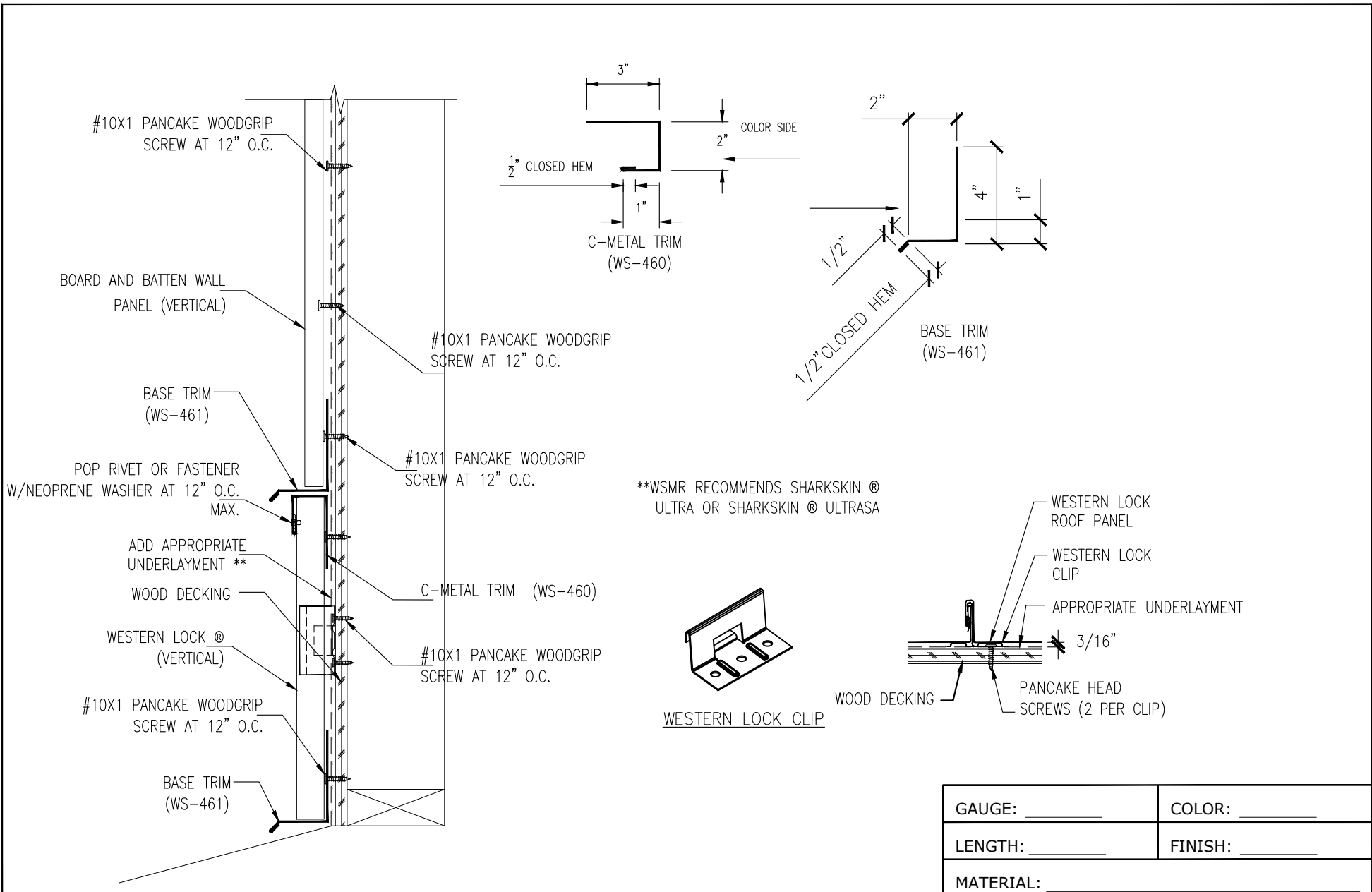

**WSMR RECOMMENDS SHARKSKIN ® ULTRA OR SHARKSKIN ® ULTRASA

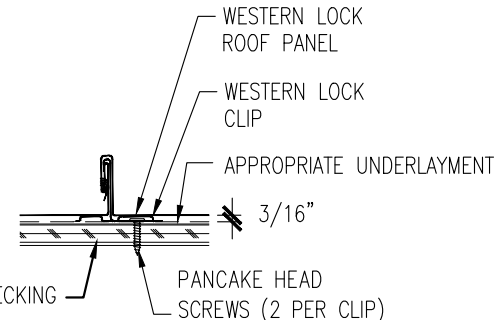
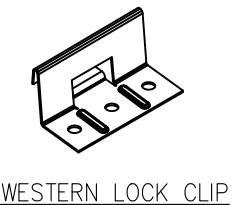

GUAGE: _____	COLOR: _____
LENGTH: _____	FINISH: _____
MATERIAL: _____	



Western States Metal Roofing

901 W. Watkins St.
 Phoenix, AZ 85007
www.westernstatesmetalroofing.com

Phone: (602) 495-0048
 Fax: (602) 261-7726
 877-PURLINS (787-5467)



WAINSCOAT TRANSITION DETAIL VERTICAL (BOARD AND BATTEN TO WESTERN LOCK ®)		
	A	7-18-2023
PANEL TYPE: BOARD AND BATTEN	REV:	DATE:
	DETAIL #: WP-WSD-W22	

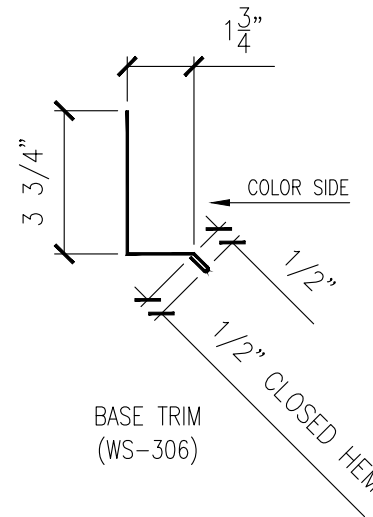
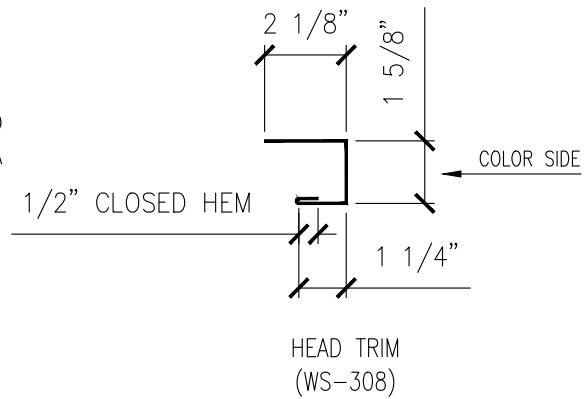
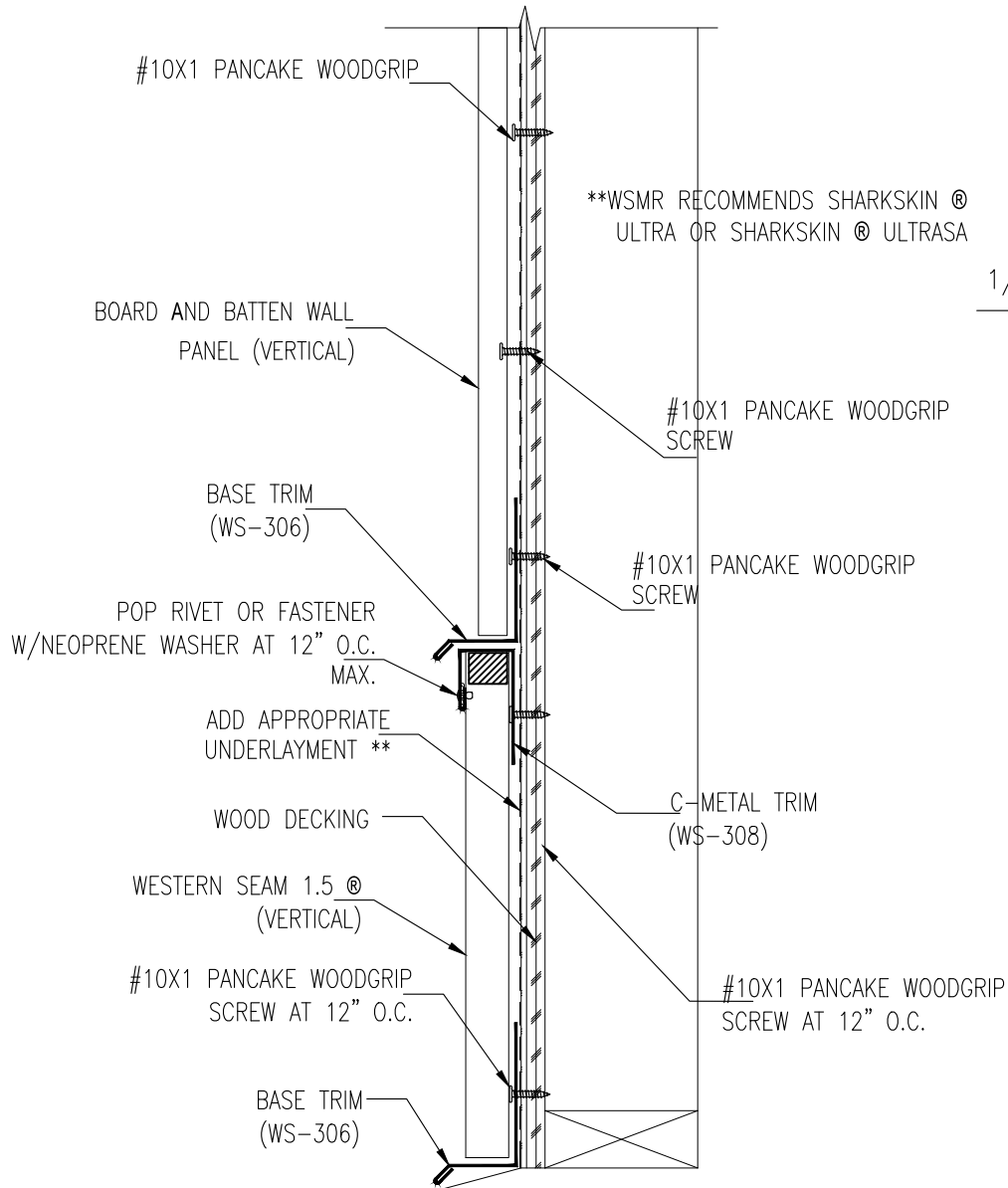

GUAGE: _____	COLOR: _____
LENGTH: _____	FINISH: _____
MATERIAL: _____	

WAINSCOT TRANSITION DETAIL VERTICAL (BOARD AND BATTEN TO WESTERN SEAM 1.5 ®)			
PANEL TYPE: BOARD AND BATTEN		A	7-18-2023
		REV:	DATE:
		DETAIL #: WP-WSD-W23	



Western States Metal Roofing

901 W. Watkins St.
Phoenix, AZ 85007
www.westernstatesmetalroofing.com

Phone: (602) 495-0048
Fax: (602) 261-7726
877-PURLINS (787-5467)



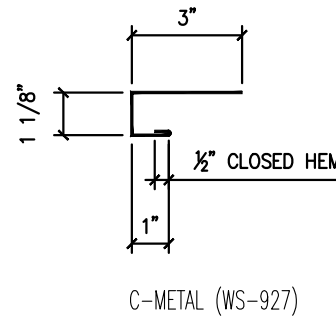
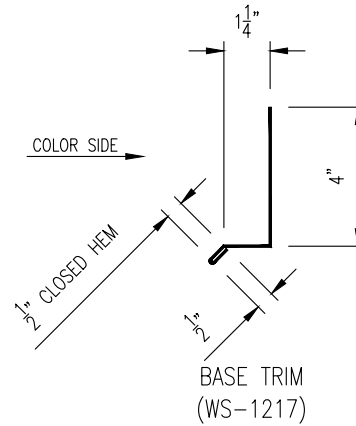
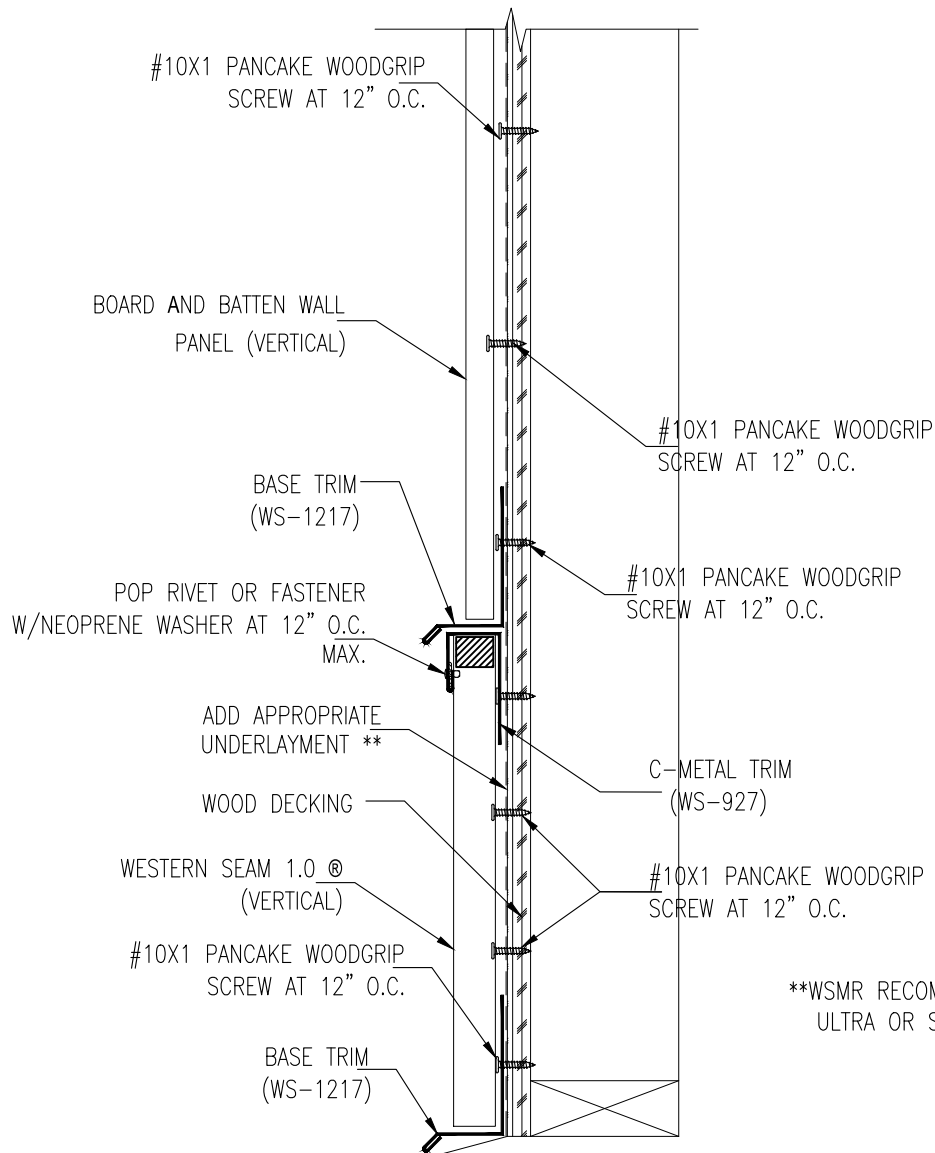

**WSMR RECOMMENDS SHARKSKIN ® ULTRA OR SHARKSKIN ® ULTRASA

GUAGE: _____	COLOR: _____
LENGTH: _____	FINISH: _____
MATERIAL: _____	

WAINSCOT TRANSITION DETAIL VERTICAL (BOARD AND BATTEN TO WESTERN SEAM 1.0 ®)			
PANEL TYPE: BOARD AND BATTEN		A	7-18-2023
		REV:	DATE:
		DETAIL #: WP-WSD-W24	



Western States Metal Roofing

901 W. Watkins St.
Phoenix, AZ 85007
www.westernstatesmetalroofing.com

Phone: (602) 495-0048
Fax: (602) 261-7726
877-PURLINS (787-5467)



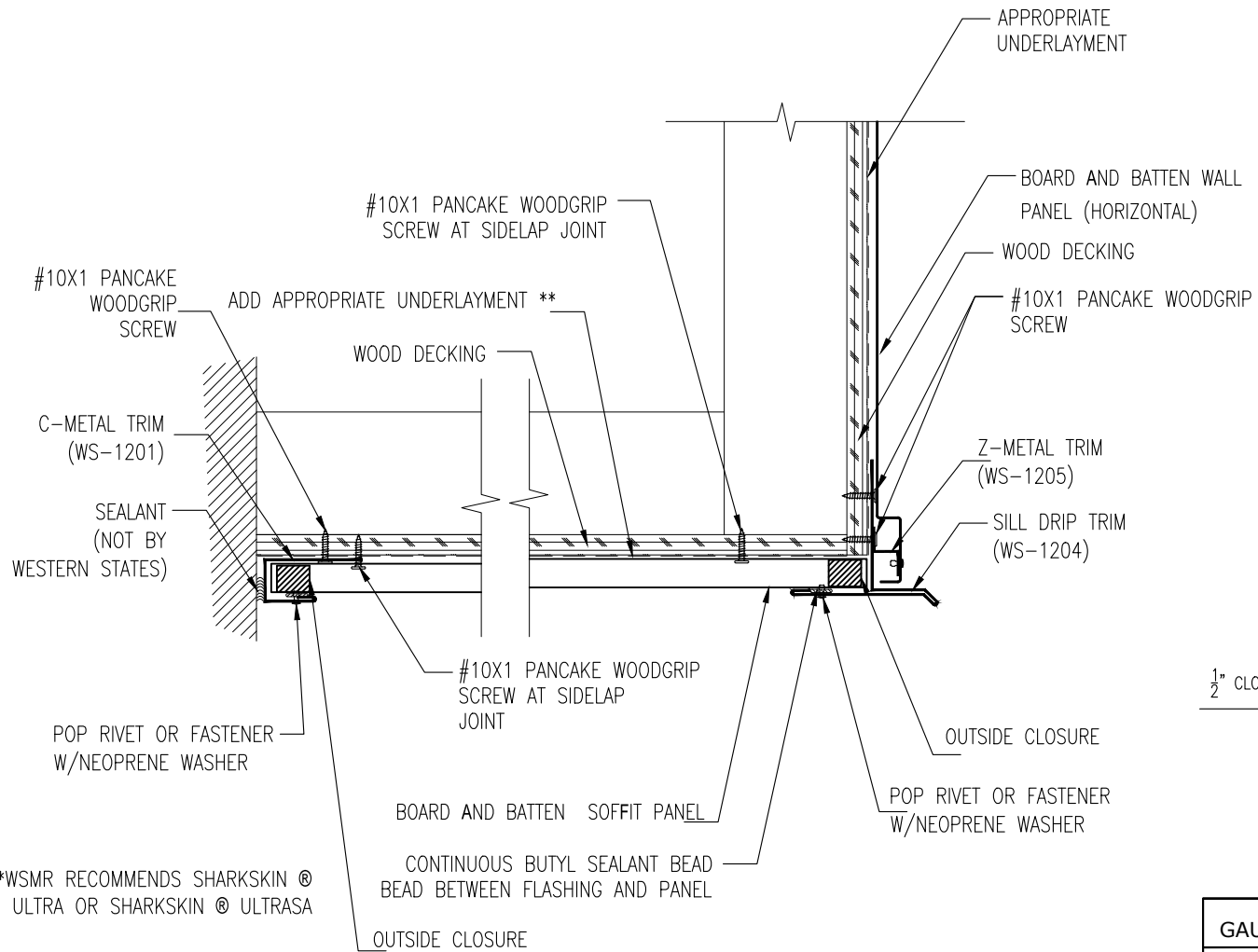

**WSMR RECOMMENDS SHARKSKIN ® ULTRA OR SHARKSKIN ® ULTRASA

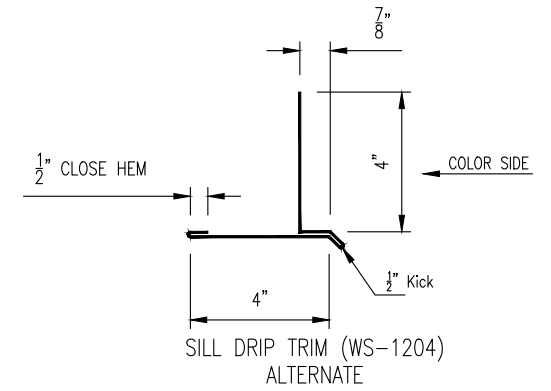
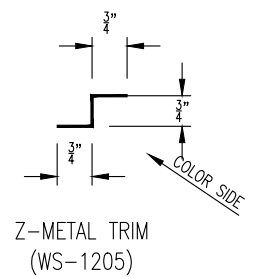
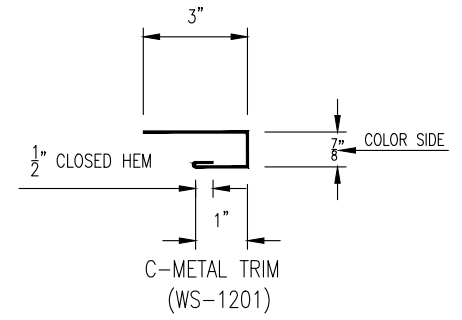

GAUGE: _____	COLOR: _____
LENGTH: _____	FINISH: _____
MATERIAL: _____	

SOFFIT TO WALL HORIZONTAL DETAIL		
	A	7-18-2023
PANEL TYPE: BOARD AND BATTEN	REV:	DATE:
	DETAIL #: WP-WSD-W25	



Western States Metal Roofing

901 W. Watkins St.
Phoenix, AZ 85007
www.westernstatesmetalroofing.com

Phone: (602) 495-0048
Fax: (602) 261-7726
877-PURLINS (787-5467)



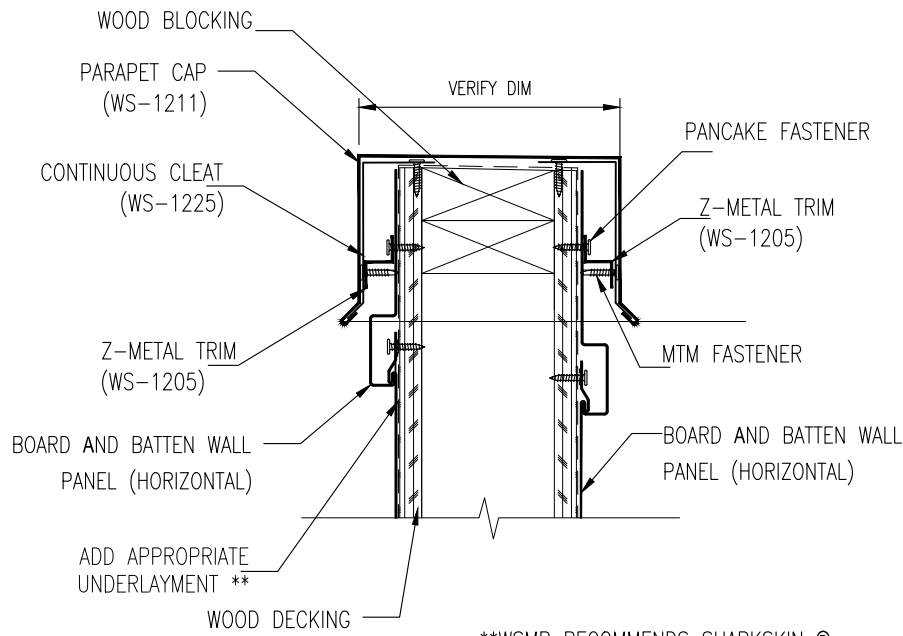

**WSMR RECOMMENDS SHARKSKIN @ ULTRA OR SHARKSKIN @ ULTRASA

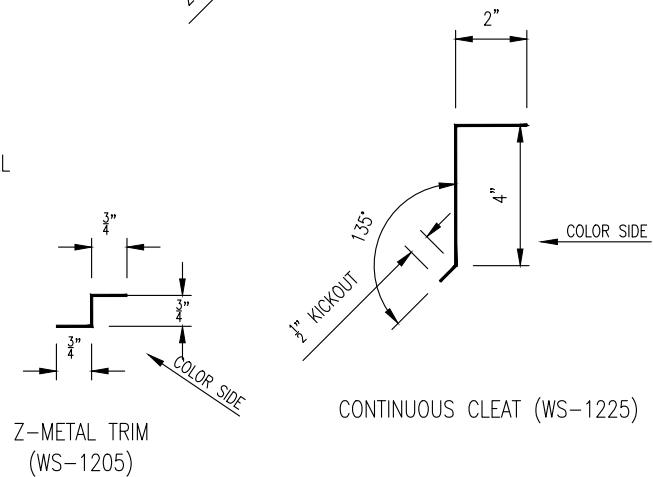
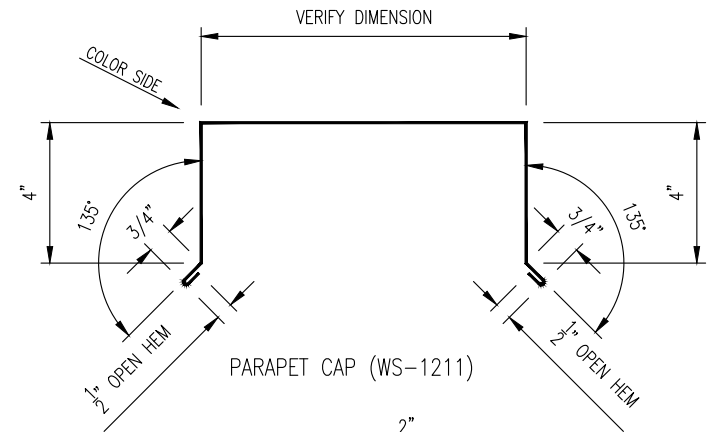

GAUGE: _____	COLOR: _____
LENGTH: _____	FINISH: _____
MATERIAL: _____	

PARAPET WALL HORIZONTAL DETAIL		
	A	7-18-2023
PANEL TYPE: BOARD AND BATTEN	REV:	DATE:
	DETAIL #: WP-WSD-W26	



Western States Metal Roofing

901 W. Watkins St.
Phoenix, AZ 85007
www.westernstatesmetalroofing.com

Phone: (602) 495-0048
Fax: (602) 261-7726
877-PURLINS (787-5467)



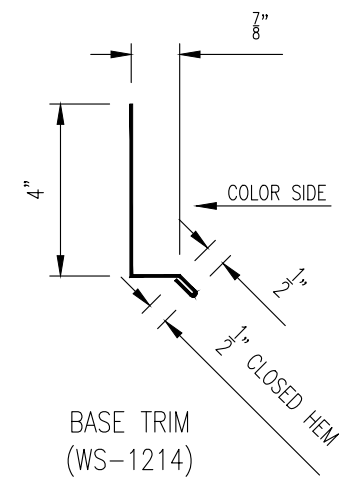
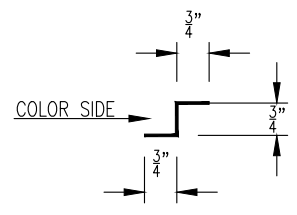
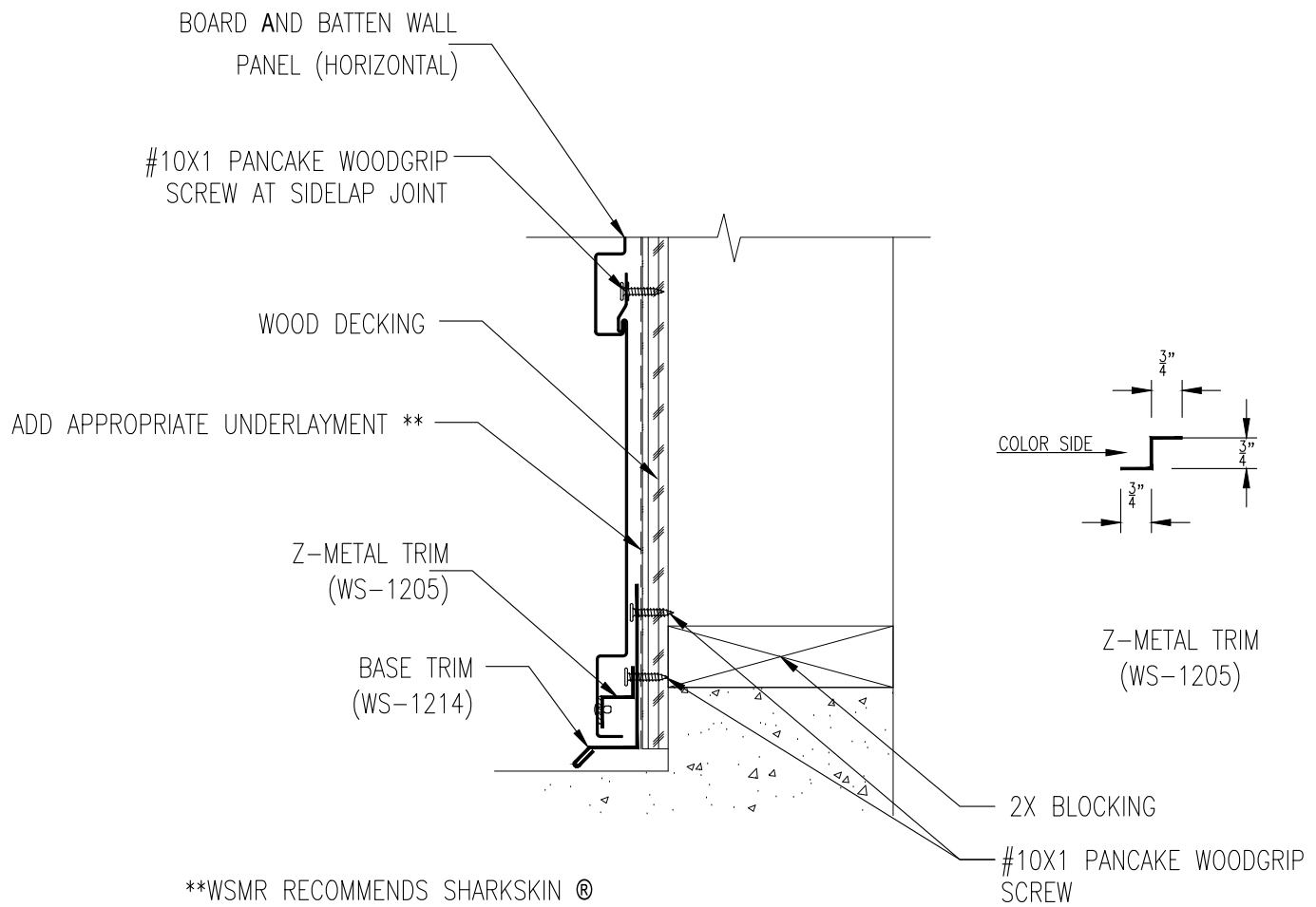

**WSMR RECOMMENDS SHARKSKIN ®
ULTRA OR SHARKSKIN ® ULTRASA

GAUGE: _____	COLOR: _____
LENGTH: _____	FINISH: _____
MATERIAL: _____	

HORIZONTAL BASE DETAIL OP 1		
	A	7-18-2023
PANEL TYPE: BOARD AND BATTEN	REV:	DATE:
	DETAIL #: WP-WSD-W27	



Western States Metal Roofing

901 W. Watkins St.
Phoenix, AZ 85007
www.westernstatesmetalroofing.com

Phone: (602) 495-0048
Fax: (602) 261-7726
877-PURLINS (787-5467)



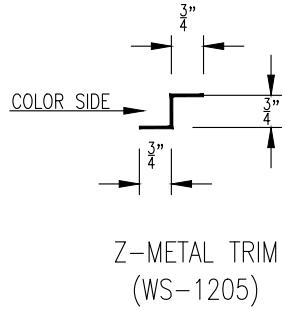
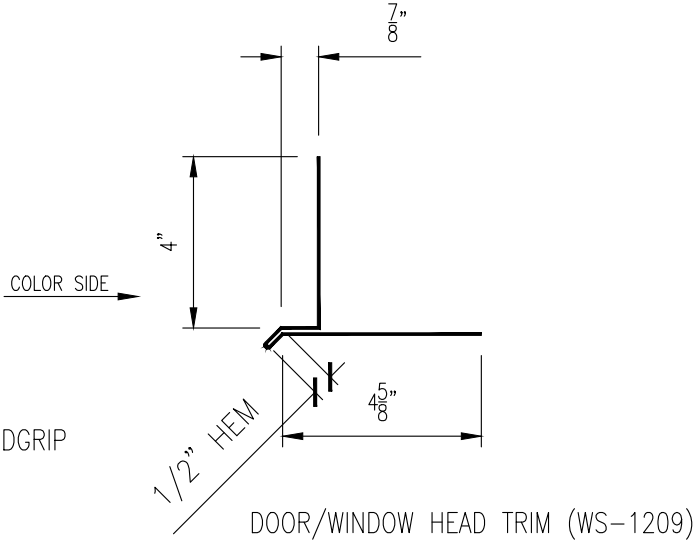
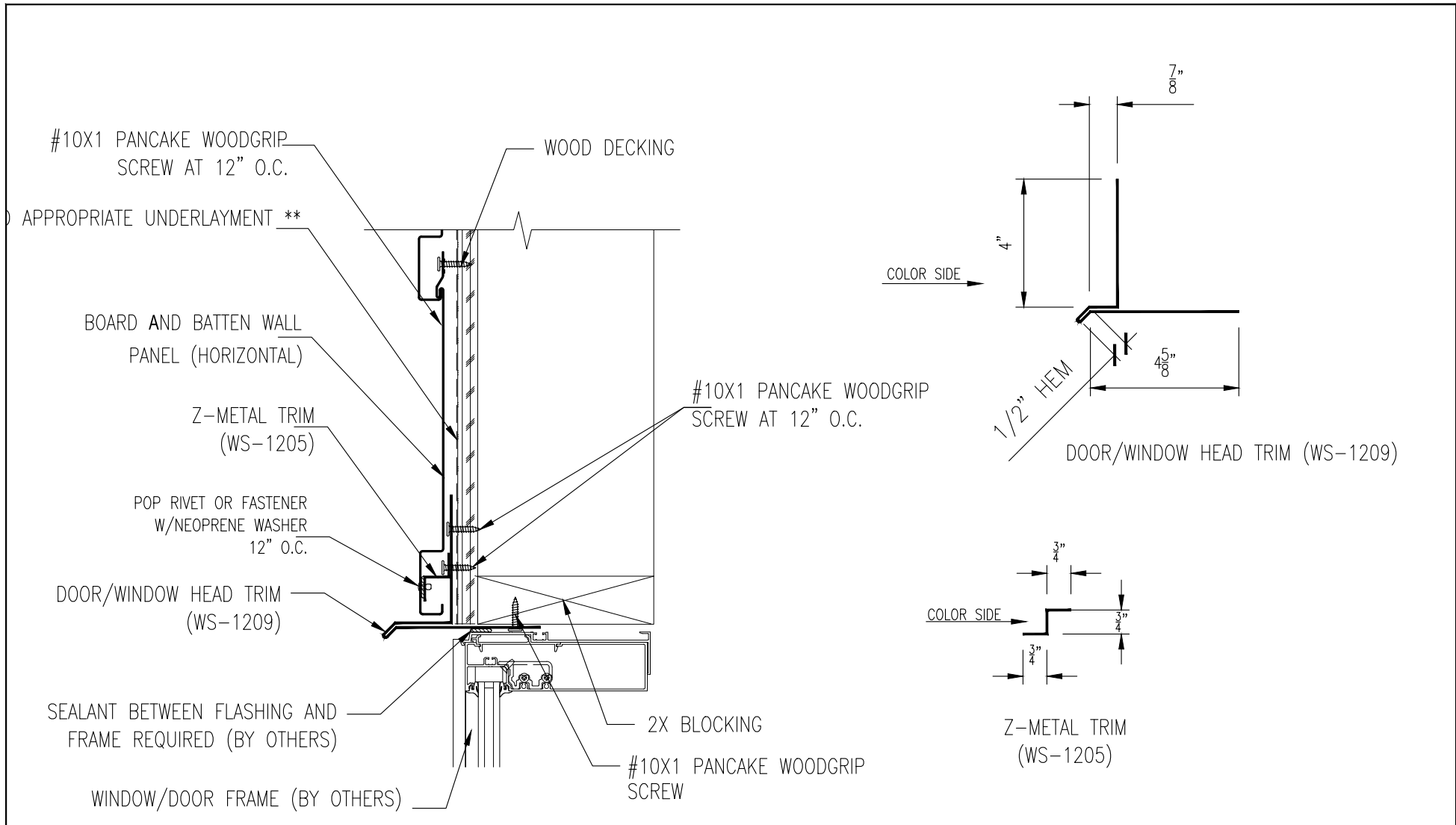

**WSMR RECOMMENDS SHARKSKIN ®
ULTRA OR SHARKSKIN ® ULTRASA

GAUGE: _____	COLOR: _____
LENGTH: _____	FINISH: _____
MATERIAL: _____	

SILL/HEAD TRIM @ WINDOW/DOOR HORIZONTAL OP 2		
	A	7-18-2023
PANEL TYPE: BOARD AND BATTEN	REV:	DATE:
	DETAIL #: WP-WSD-W28	



Western States Metal Roofing

901 W. Watkins St.
Phoenix, AZ 85007
www.westernstatesmetalroofing.com

Phone: (602) 495-0048
Fax: (602) 261-7726
877-PURLINS (787-5467)



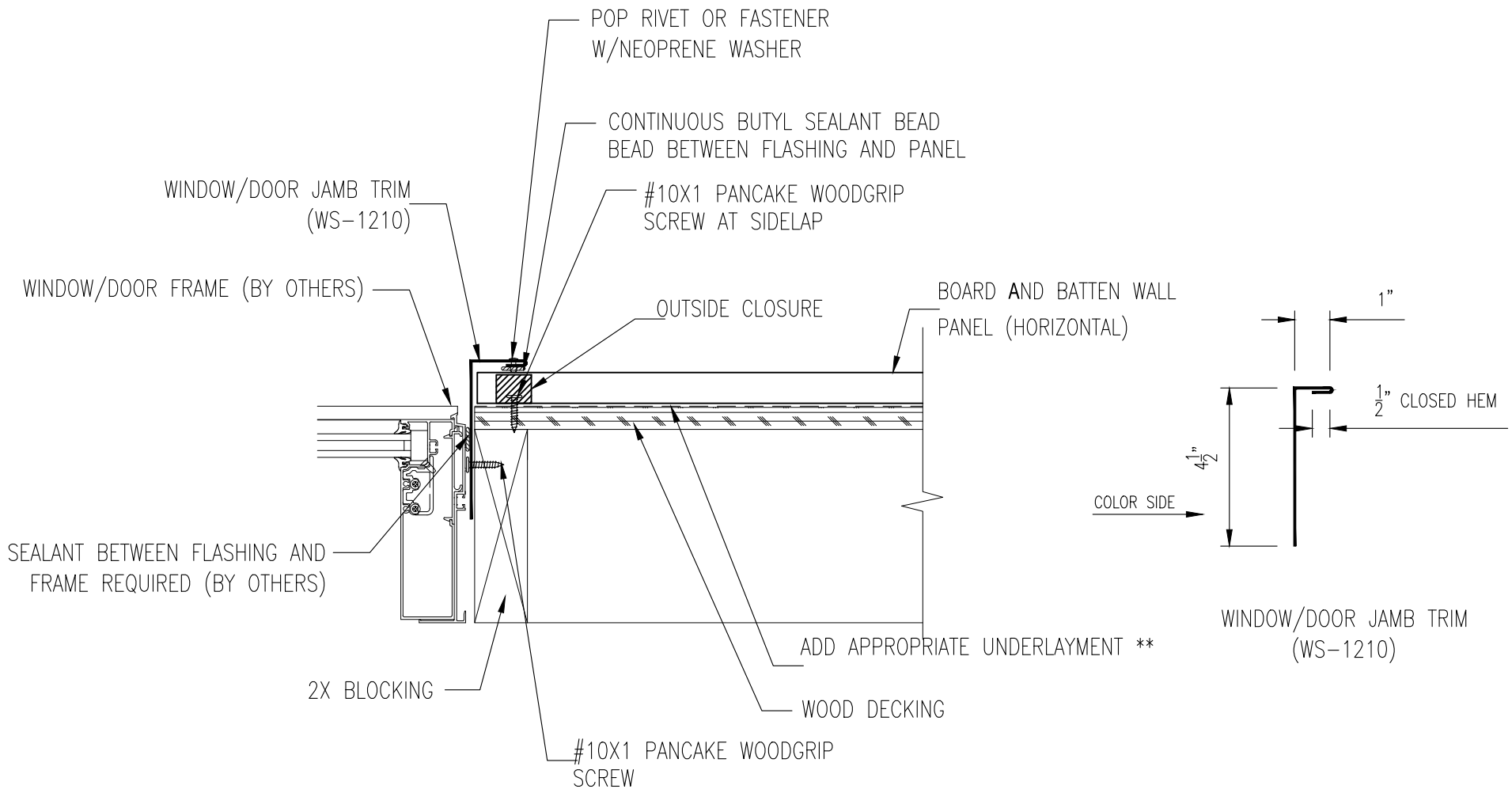

**WSMR RECOMMENDS SHARKSKIN ®
ULTRA OR SHARKSKIN ® ULTRASA

GAUGE: _____	COLOR: _____
LENGTH: _____	FINISH: _____
MATERIAL: _____	
JAMB TRIM @ WINDOW / DOOR HORIZONTAL OP1	
A	7-18-2023
REV:	DATE:
PANEL TYPE: BOARD AND BATTEN	DETAIL #: WP-WSD-W29



Western States Metal Roofing

901 W. Watkins St.
Phoenix, AZ 85007
www.westernstatesmetalroofing.com

Phone: (602) 495-0048
Fax: (602) 261-7726
877-PURLINS (787-5467)



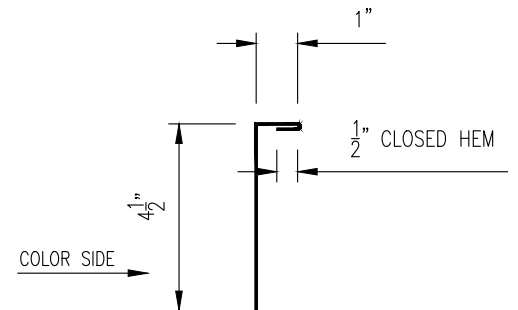
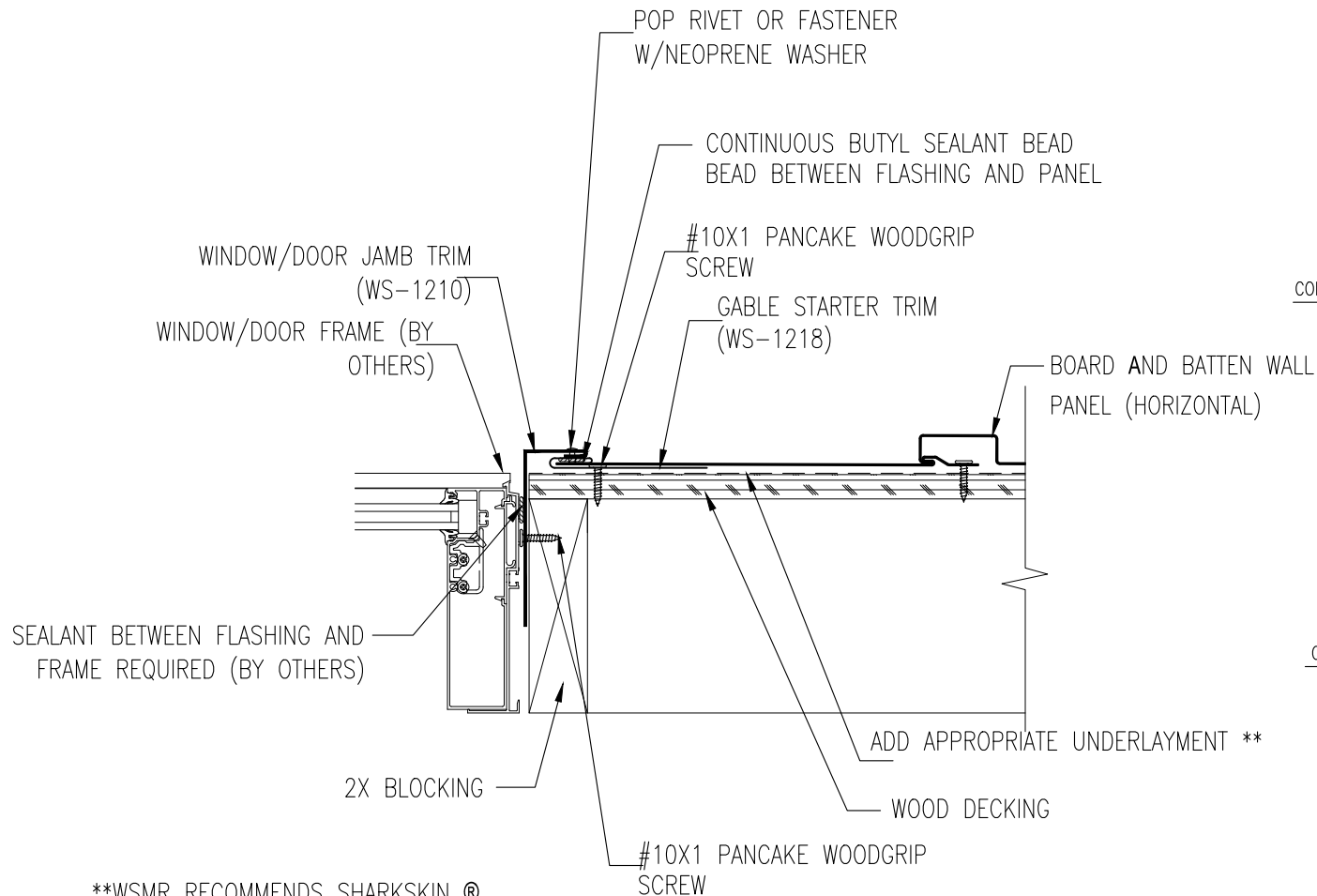

WINDOW/DOOR JAMB TRIM (WS-1210)

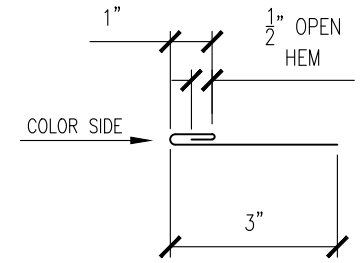

GABLE STARTER TRIM (WS-1218)

**WSMR RECOMMENDS SHARKSKIN ® ULTRA OR SHARKSKIN ® ULTRASA

GAUGE: _____	COLOR: _____
LENGTH: _____	FINISH: _____
MATERIAL: _____	
JAMB TRIM @ WINDOW / DOOR VERTICAL OP2	
	A 7-18-2023
PANEL TYPE: BOARD AND BATTEN	REV: DATE:
	DETAIL #: WP-WSD-W30



Western States Metal Roofing

901 W. Watkins St.
Phoenix, AZ 85007
www.westernstatesmetalroofing.com

Phone: (602) 495-0048
Fax: (602) 261-7726
877-PURLINS (787-5467)



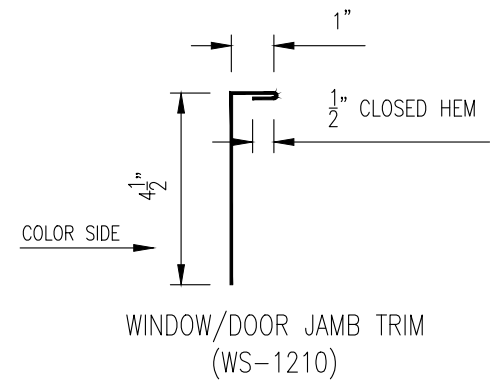
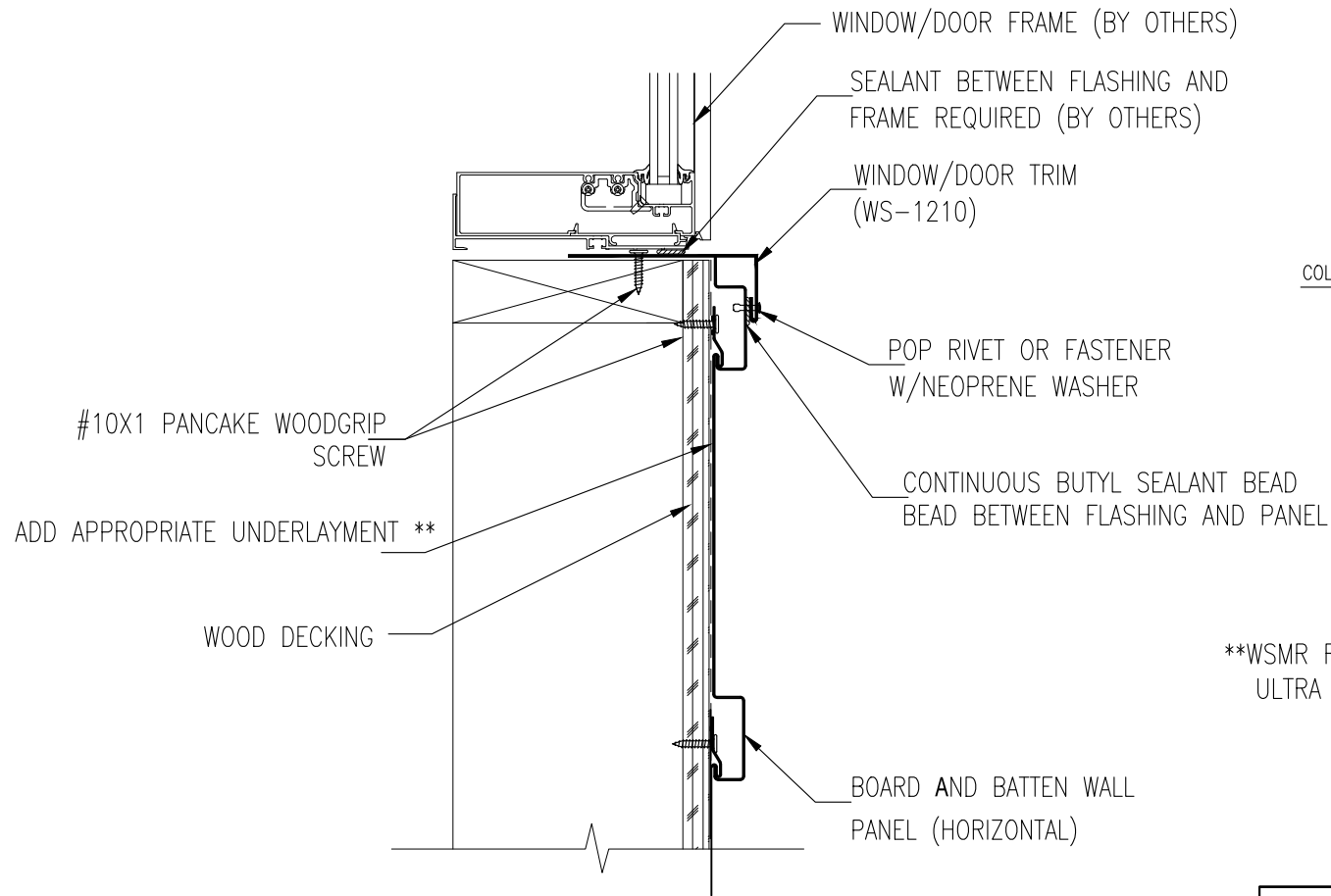

**WSMR RECOMMENDS SHARKSKIN ® ULTRA OR SHARKSKIN ® ULTRASA

GAUGE: _____	COLOR: _____
LENGTH: _____	FINISH: _____
MATERIAL: _____	
SILL TRIM @ WINDOW / DOOR HORIZONTAL	
A	7-18-2023
REV:	DATE:
DETAIL #: WP-WSD-W31	
PANEL TYPE: BOARD AND BATTEN	



Western States Metal Roofing

901 W. Watkins St.
Phoenix, AZ 85007

www.westernstatesmetalroofing.com

Phone: (602) 495-0048

Fax: (602) 261-7726

877-PURLINS (787-5467)



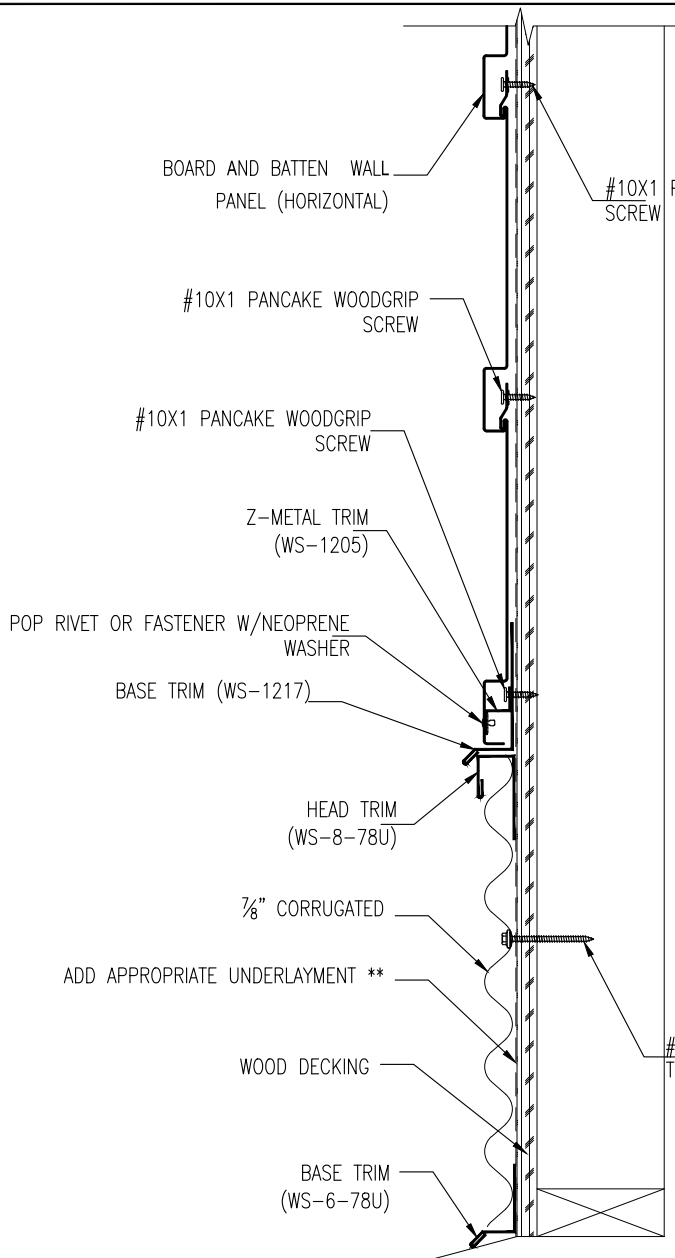

BOARD AND BATTEN WALL
PANEL (HORIZONTAL)

#10X1 PANCAKE WOODGRIP SCREW

#10X1 PANCAKE WOODGRIP SCREW

#10X1 PANCAKE WOODGRIP SCREW

Z-METAL TRIM
(WS-1205)

POP RIVET OR FASTENER W/NEOPRENE WASHER

BASE TRIM (WS-1217)

HEAD TRIM
(WS-8-78U)

7/8" CORRUGATED

ADD APPROPRIATE UNDERLAYMENT **

WOOD DECKING

BASE TRIM
(WS-6-78U)

#9X1 WOOD SCREW
TBD HEX HEAD.

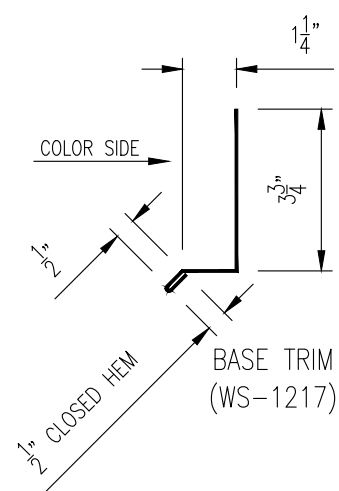

COLOR SIDE

BASE TRIM
(WS-1217)

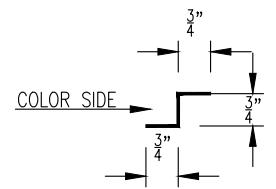

COLOR SIDE

Z-METAL TRIM
(WS-1205)

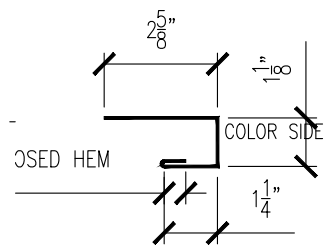

CLOSED HEM

COLOR SIDE

HEAD TRIM
(WS-8-78U)

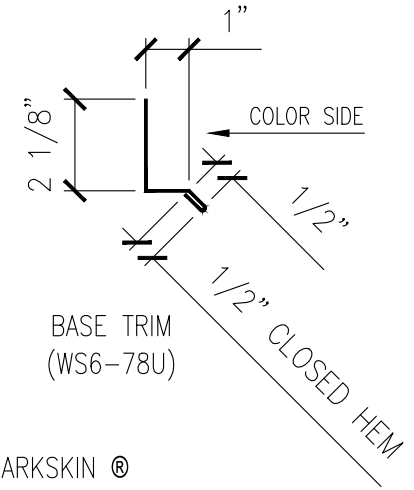

COLOR SIDE

BASE TRIM
(WS6-78U)

**WSMR RECOMMENDS SHARKSKIN ®
ULTRA OR SHARKSKIN ® ULTRASA

GUAGE: _____	COLOR: _____
LENGTH: _____	FINISH: _____
MATERIAL: _____	



Western States Metal Roofing

901 W. Watkins St.
Phoenix, AZ 85007
www.westernstatesmetalroofing.com

Phone: (602) 495-0048
Fax: (602) 261-7726
877-PURLINS (787-5467)



WAINSCOT HORIZONTAL TRANSITION DETAIL (BOARD AND BATTEN TO 7/8" CORRUGATED)		
	A	7-18-2023
PANEL TYPE: BOARD AND BATTEN	REV:	DATE:
	DETAIL #: WP-WSD-W32	

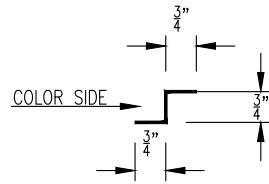
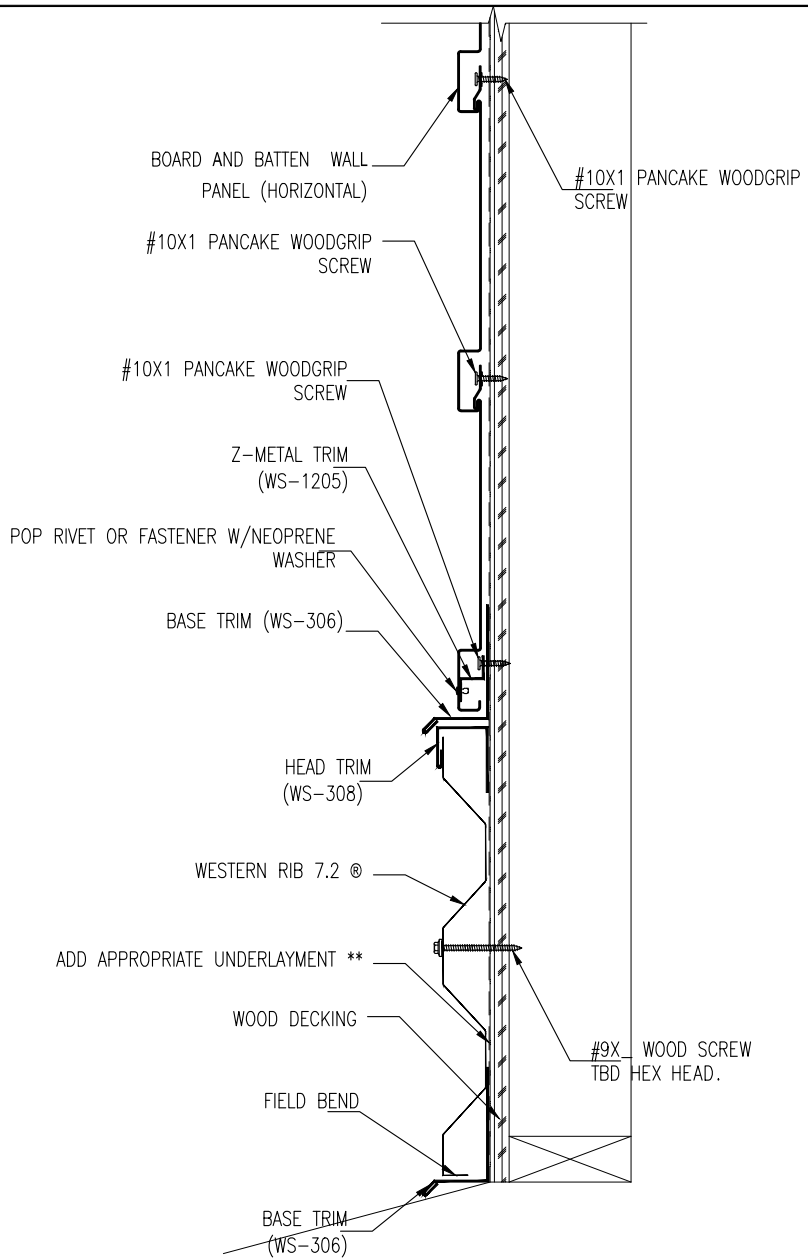

Z-METAL TRIM
(WS-1205)

**WSMR RECOMMENDS SHARKSKIN®
ULTRA OR SHARKSKIN® ULTRASA

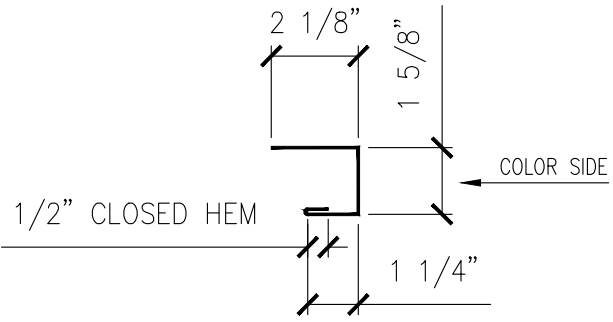

HEAD TRIM
(WS-308)

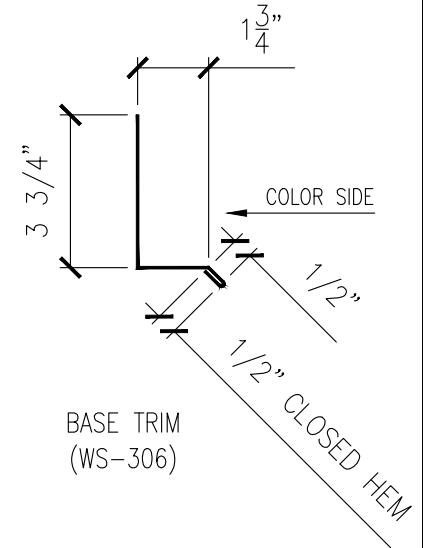

BASE TRIM
(WS-306)

GAUGE: _____	COLOR: _____
LENGTH: _____	FINISH: _____
MATERIAL: _____	

WAINSCOT HORIZONTAL TRANSITION DETAIL (BOARD AND BATTEN TO WESTERN RIB)		
	A	7-18-2023
PANEL TYPE: BOARD AND BATTEN	REV:	DATE:
	DETAIL #: WP-WSD-W33	



Western States Metal Roofing

901 W. Watkins St.
Phoenix, AZ 85007
www.westernstatesmetalroofing.com

Phone: (602) 495-0048
Fax: (602) 261-7726
877-PURLINS (787-5467)



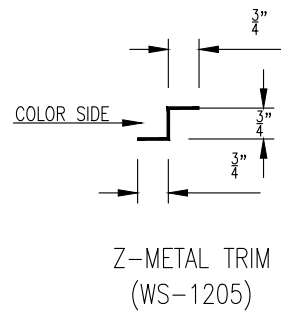
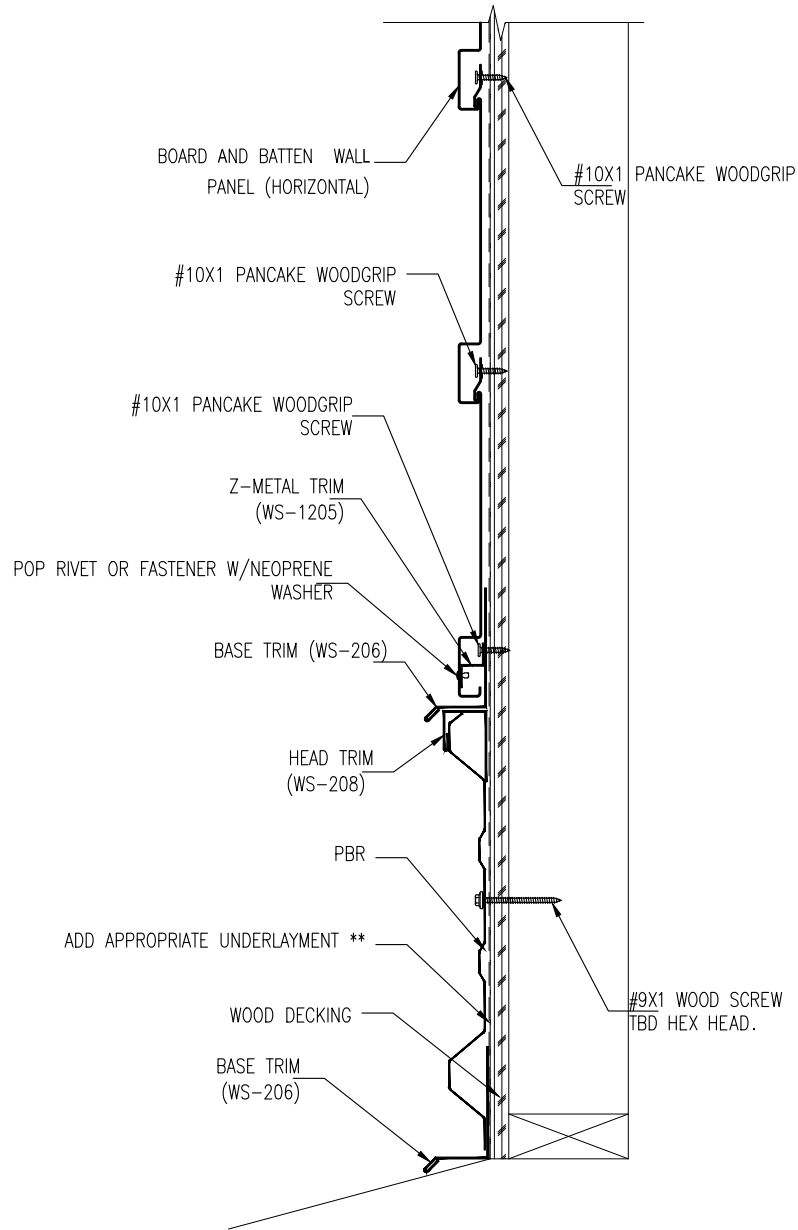

**WSMR RECOMMENDS SHARKSKIN ® ULTRA OR SHARKSKIN ® ULTRASA

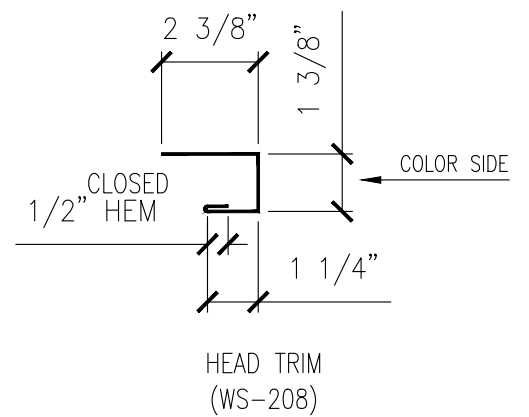
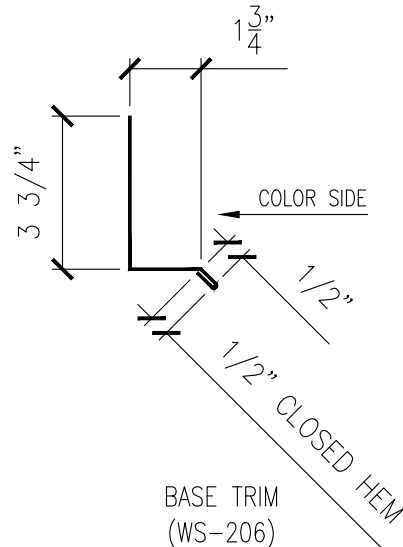

GUAGE: _____	COLOR: _____
LENGTH: _____	FINISH: _____
MATERIAL: _____	

WAINSCOT HORIZONTAL TRANSITION DETAIL (BOARD AND BATTEN TO PBR)			
PANEL TYPE: BOARD AND BATTEN		A	7-18-2023
		REV:	DATE:
		DETAIL #: WP-WSD-W34	



Western States Metal Roofing

901 W. Watkins St.
Phoenix, AZ 85007
www.westernstatesmetalroofing.com

Phone: (602) 495-0048
Fax: (602) 261-7726
877-PURLINS (787-5467)



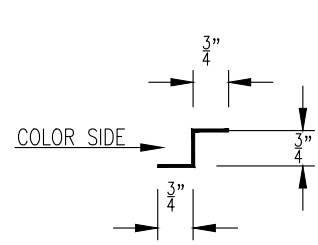
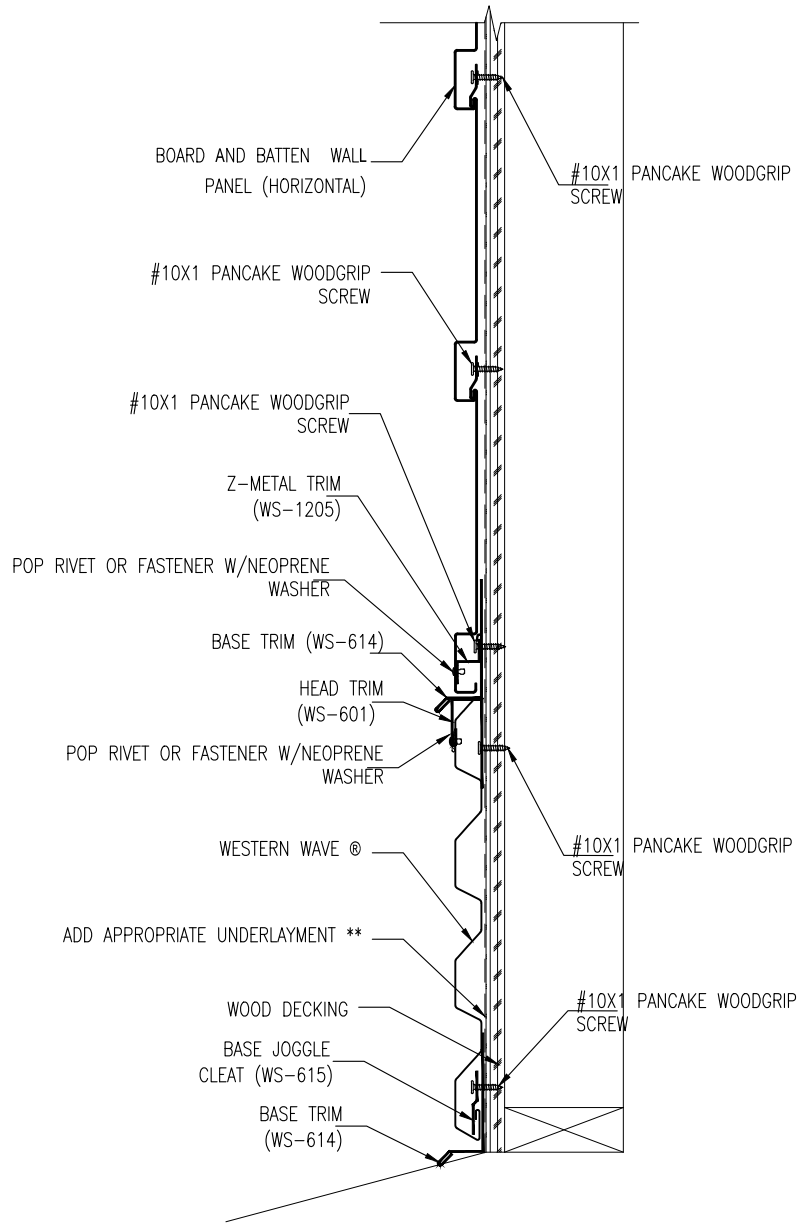

Z-METAL TRIM (WS-1205)

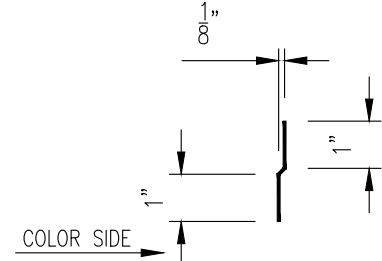

BASE JOGGLE CLEAT (WS-615)

**WSMR RECOMMENDS SHARKSKIN® ULTRA OR SHARKSKIN® ULTRASA

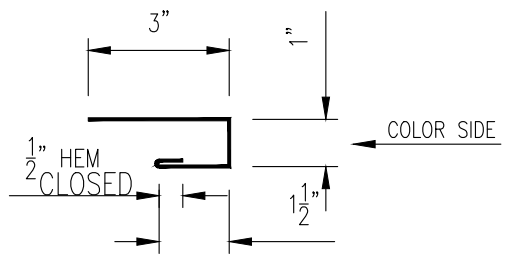

C-METAL TRIM (WS-601)

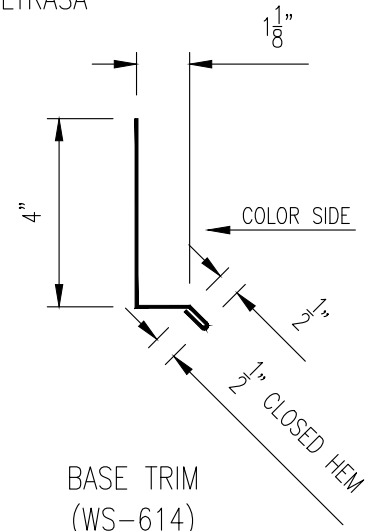

BASE TRIM (WS-614)

GUAGE: _____	COLOR: _____
LENGTH: _____	FINISH: _____
MATERIAL: _____	



Western States Metal Roofing

901 W. Watkins St.
 Phoenix, AZ 85007
www.westernstatesmetalroofing.com

Phone: (602) 495-0048
 Fax: (602) 261-7726
 877-PURLINS (787-5467)



WAINSCOT HORIZONTAL TRANSITION DETAIL (BOARD AND BATTEN TO WESTERN WAVE®)		
	A	7-18-2023
PANEL TYPE: BOARD AND BATTEN	REV:	DATE:
	DETAIL #: WP-WSD-W35	

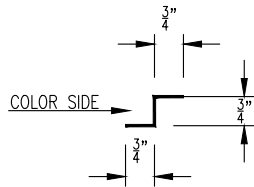
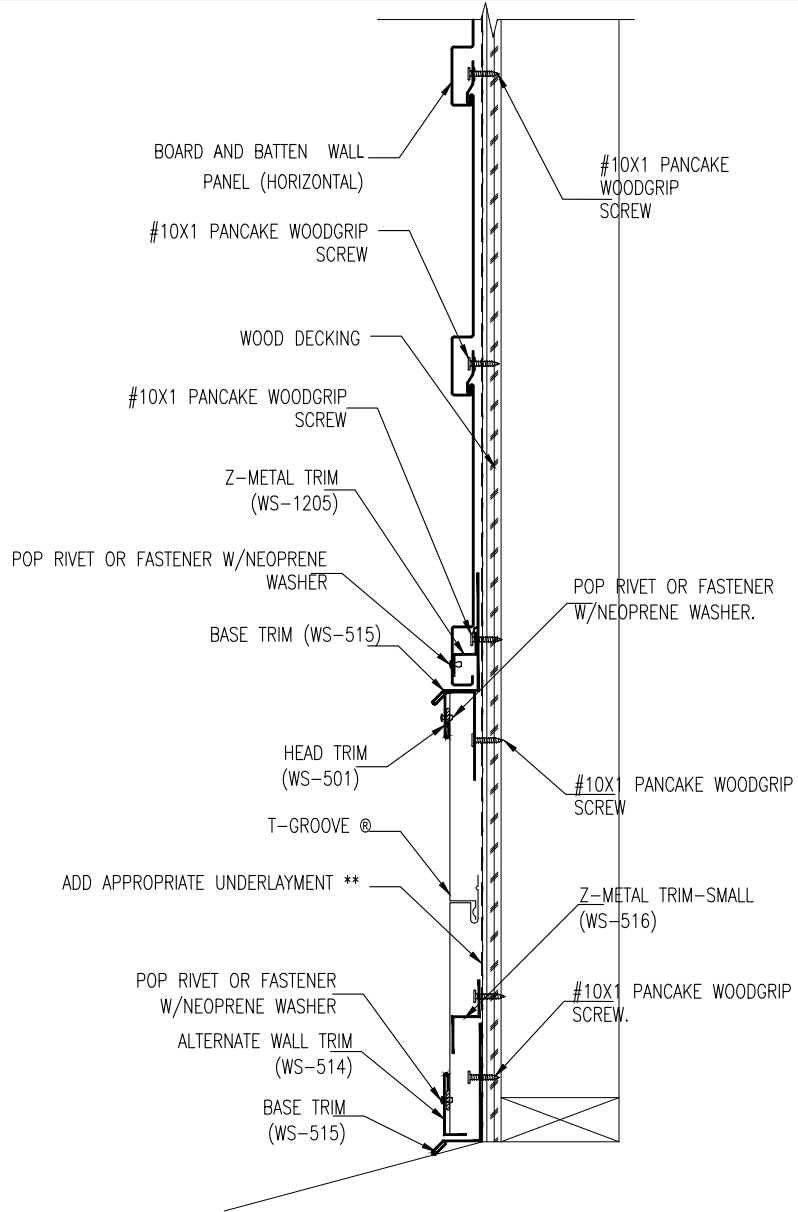

Z-METAL TRIM (WS-1205)

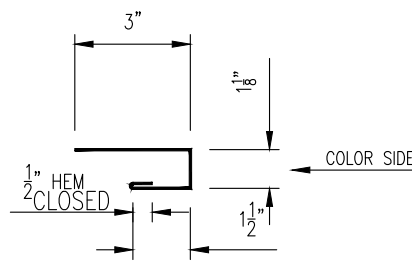

C-METAL TRIM (WS-501)

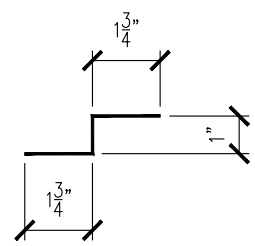

Z-METAL TRIM (SMALL) (WS-516)

**WSMR RECOMMENDS SHARKSKIN ® ULTRA OR SHARKSKIN ® ULTRASA

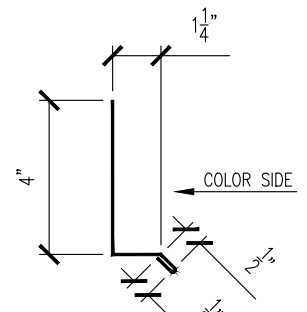

BASE TRIM (WS-515)

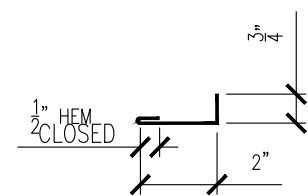

ALTERNATE WALL TRIM (WS-514)

GUAGE: _____	COLOR: _____
LENGTH: _____	FINISH: _____
MATERIAL: _____	

WAINCOAT HORIZONTAL TRANSITION DETAIL (BOARD AND BATTEN TO T-GROOVE ®)	A	7-18-2023
	REV:	DATE:
PANEL TYPE: BOARD AND BATTEN	DETAIL #: WP-WSD-W36	



Western States Metal Roofing

901 W. Watkins St.
Phoenix, AZ 85007
www.westernstatesmetalroofing.com

Phone: (602) 495-0048
Fax: (602) 261-7726
877-PURLINS (787-5467)



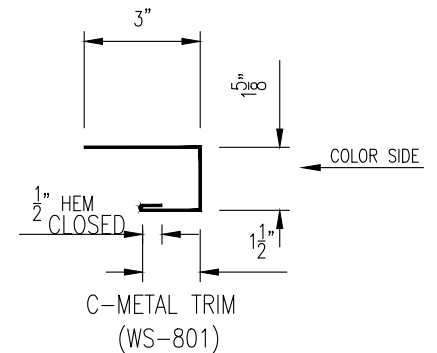
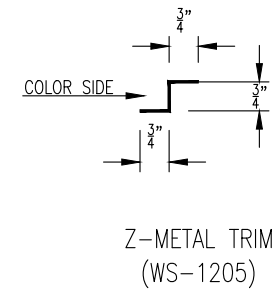
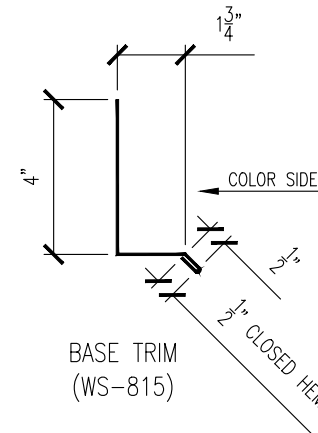
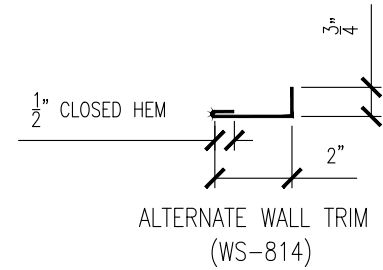
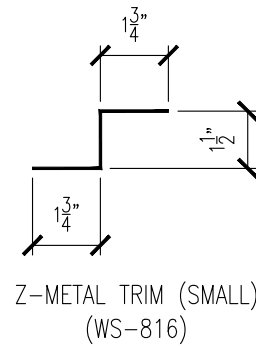
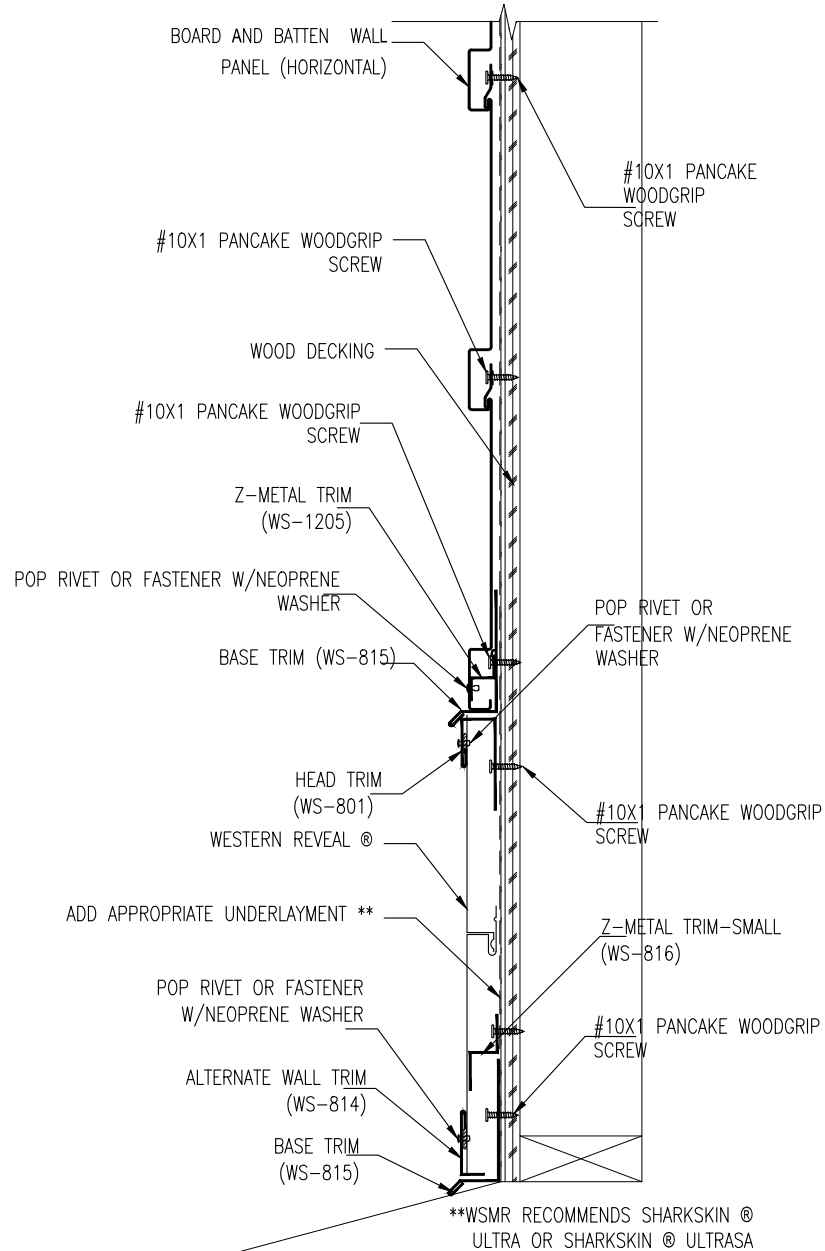

GUAGE: _____	COLOR: _____
LENGTH: _____	FINISH: _____
MATERIAL: _____	

WAINSCOAT HORIZONTAL TRANSITION DETAIL (BOARD AND BATTEN TO WESTERN REVEAL ®)			
PANEL TYPE: BOARD AND BATTEN		A	7-18-2023
		REV:	DATE:
		DETAIL #: WP-WSD-W37	



Western States Metal Roofing

901 W. Watkins St.
Phoenix, AZ 85007

www.westernstatesmetalroofing.com

Phone: (602) 495-0048

Fax: (602) 261-7726

877-PURLINS (787-5467)



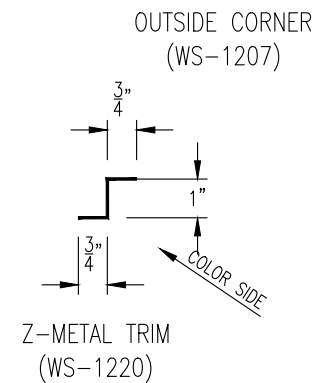
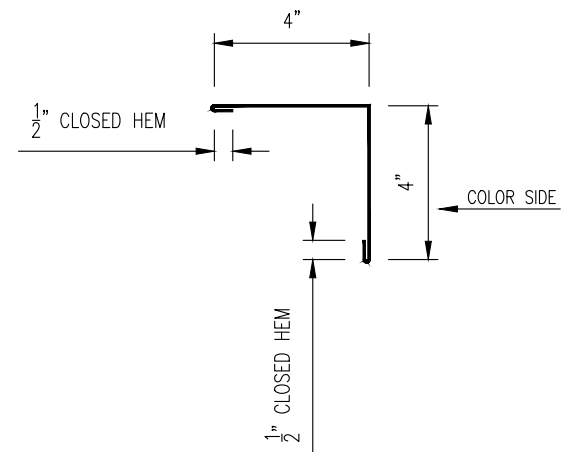
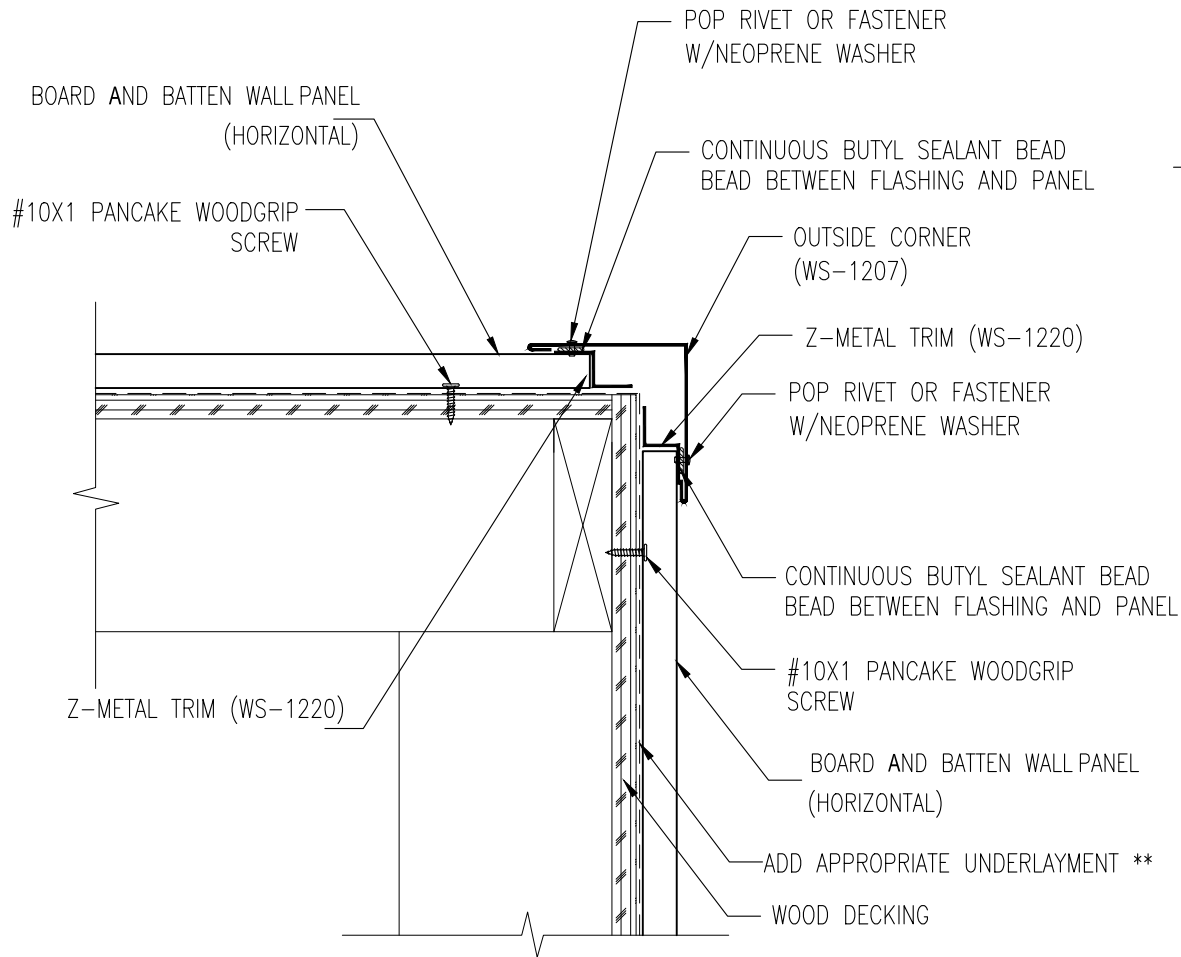

**WSMR RECOMMENDS SHARKSKIN ®
ULTRA OR SHARKSKIN ® ULTRASA

GUAGE: _____	COLOR: _____
LENGTH: _____	FINISH: _____
MATERIAL: _____	

OUTSIDE CORNER HORIZONTAL DETAIL		
	A	7-18-2023
PANEL TYPE: BOARD AND BATTEN	REV:	DATE:
	DETAIL #: WP-WSD-W38	



Western States Metal Roofing

901 W. Watkins St.
Phoenix, AZ 85007
www.westernstatesmetalroofing.com

Phone: (602) 495-0048
Fax: (602) 261-7726
877-PURLINS (787-5467)



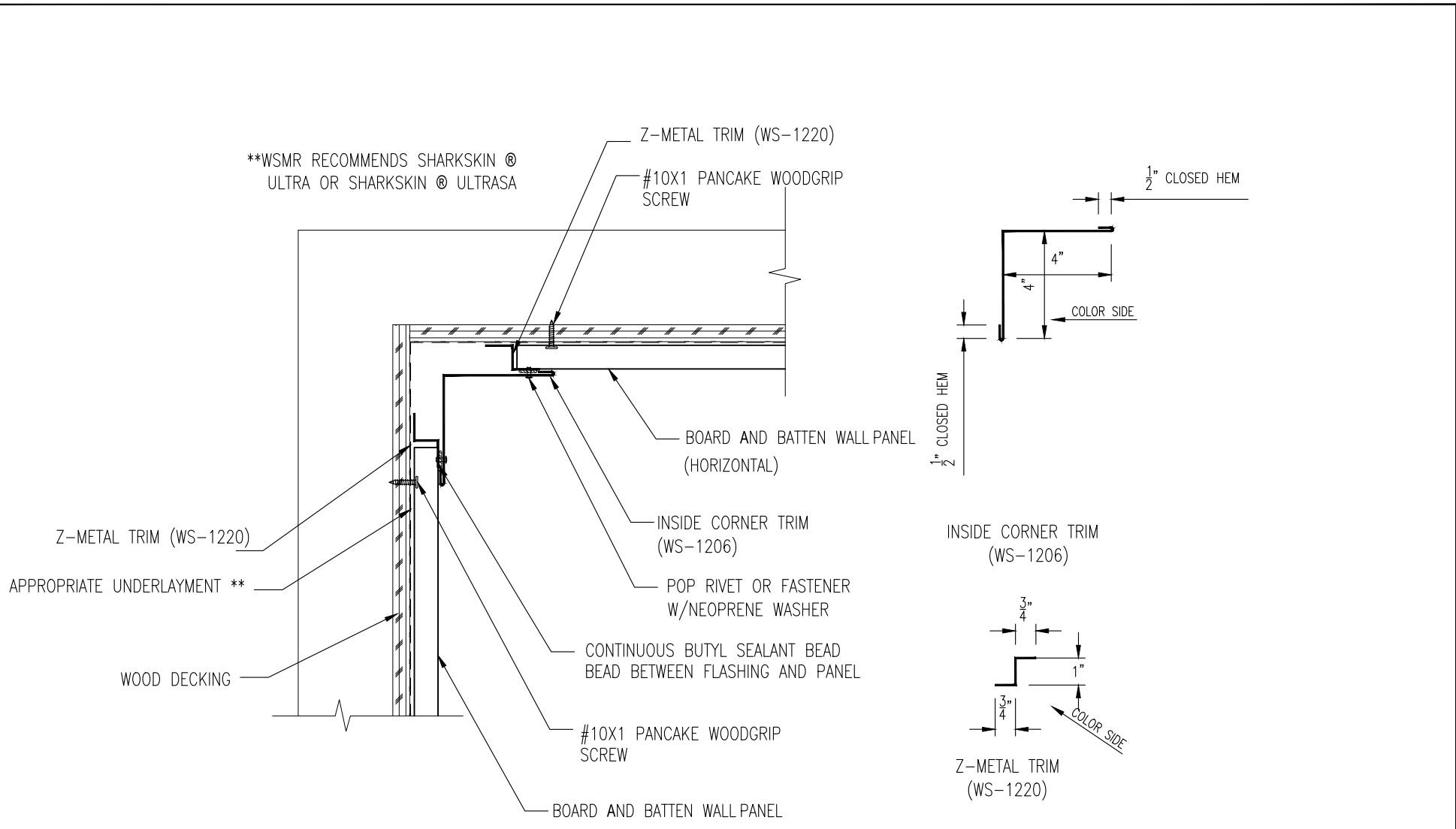

GAUGE: _____	COLOR: _____
LENGTH: _____	FINISH: _____
MATERIAL: _____	

INSIDE CORNER HORIZONTAL DETAIL		
	A	7-18-2023
PANEL TYPE: BOARD AND BATTEN	REV:	DATE:
	DETAIL #: WP-WSD-W39	



Western States Metal Roofing

901 W. Watkins St.
Phoenix, AZ 85007
www.westernstatesmetalroofing.com

Phone: (602) 495-0048
Fax: (602) 261-7726
877-PURLINS (787-5467)



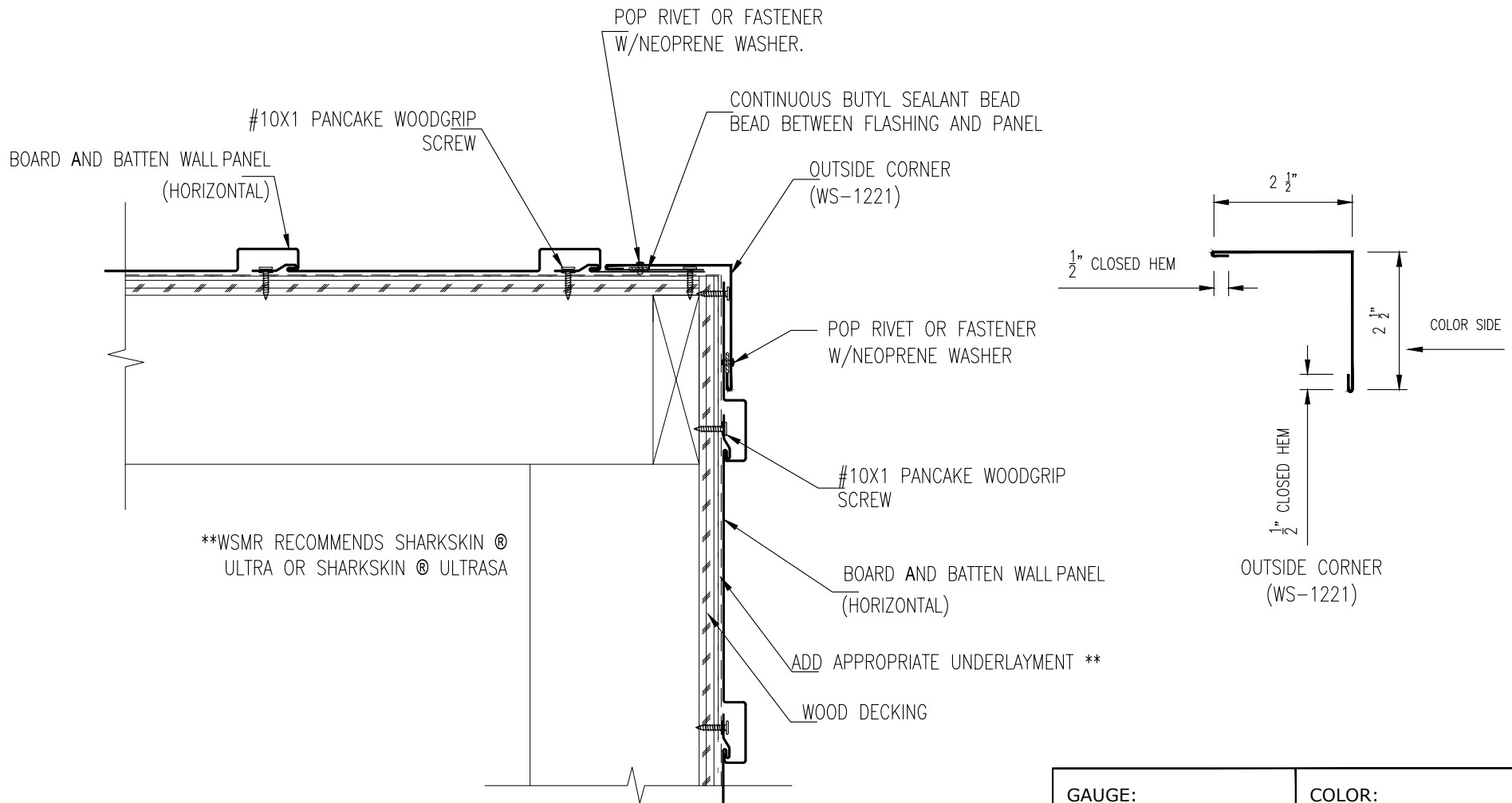

GAUGE: _____	COLOR: _____
LENGTH: _____	FINISH: _____
MATERIAL: _____	
OUTSIDE CORNER VERTICAL DETAIL OP.2	
A	7-18-2023
REV:	DATE:
PANEL TYPE: BOARD AND BATTEN	DETAIL #: WP-WSD-W40



Western States Metal Roofing

901 W. Watkins St.
Phoenix, AZ 85007
www.westernstatesmetalroofing.com

Phone: (602) 495-0048
Fax: (602) 261-7726
877-PURLINS (787-5467)



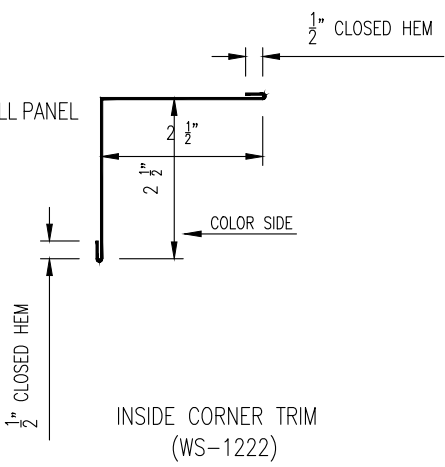
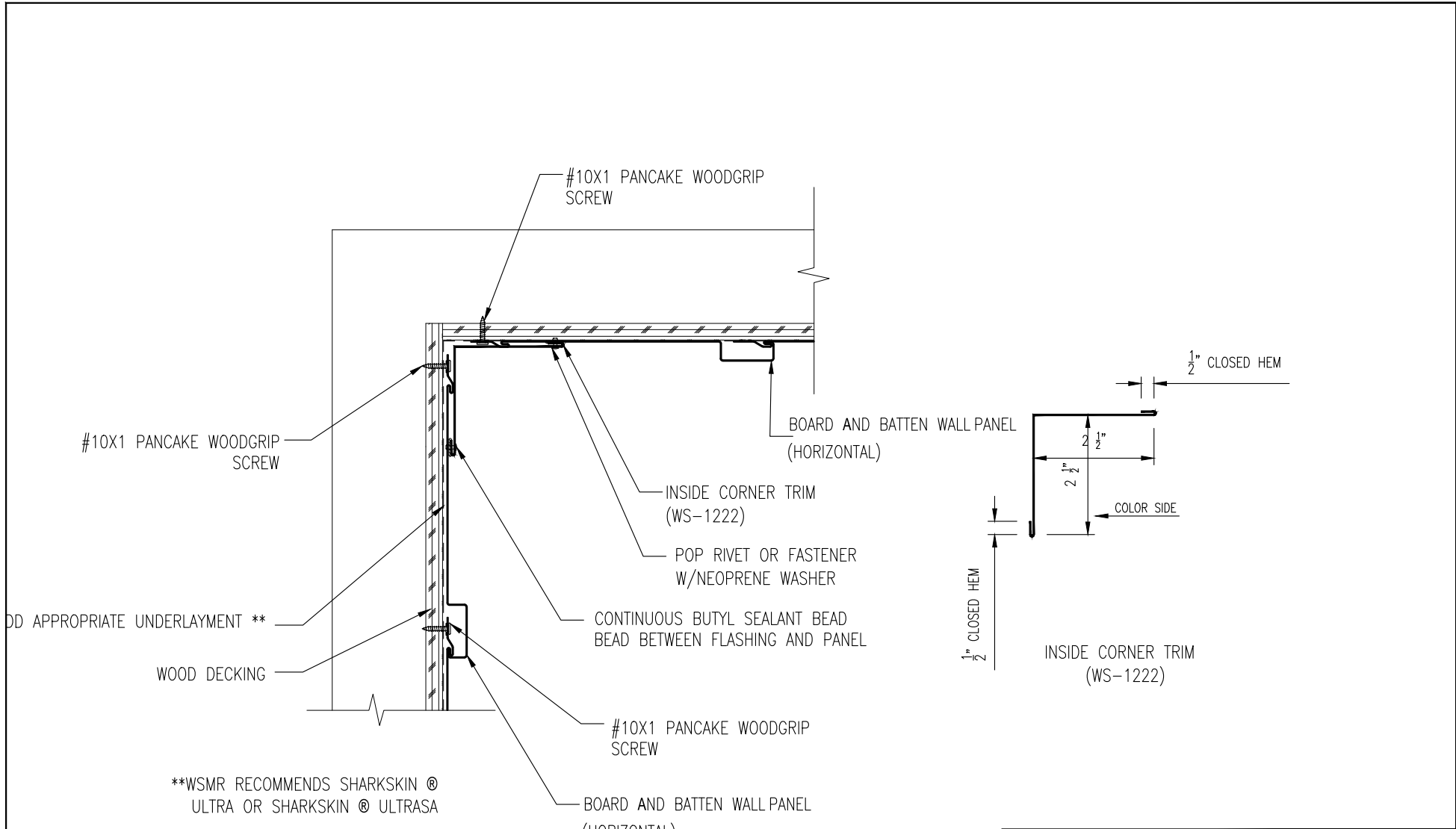

GAUGE: _____	COLOR: _____
LENGTH: _____	FINISH: _____
MATERIAL: _____	

INSIDE CORNER VERTICAL DETAIL OP 2		
	A	7-18-2023
PANEL TYPE: BOARD AND BATTEN	REV:	DATE:
	DETAIL #: WP-WSD-W41	



Western States Metal Roofing

901 W. Watkins St.
Phoenix, AZ 85007
www.westernstatesmetalroofing.com

Phone: (602) 495-0048
Fax: (602) 261-7726
877-PURLINS (787-5467)



CUSTOM TRIM

GAUGE: _____	COLOR: _____	
BREAKS: _____	FINISH: _____	
LENGTH: _____	STRETCH OUT: _____	
MATERIAL: _____		
CUSTOM TRIM NAME: _____		
	A	07-18-2023
PANEL TYPE: BB-12	REV:	DATE:
	DETAIL #: WP-WSD-CT42	



Western States Metal Roofing

901 W. Watkins St.
Phoenix, AZ 85007
www.westernstatesmetalroofing.com

Phone: (602) 495-0048
Fax: (602) 261-7726
877-PURLINS (787-5467)





Finishes You've Never Seen Before®

WESTERN STATES METAL ROOFING

(877) 787-5467 • WESTERNSTATESMETALROOFING.COM

REQUEST A FREE METAL COLOR SAMPLE • Affordable Delivery throughout USA, Canada, and Mexico

Phoenix: 901 W Watkins St., Phoenix, AZ 85007

☎ (602) 495-0048

✉ sales@westernstatesmetalroofing.com

Tucson: 4975 E. Drexel Rd., Tucson, AZ 85706

☎ (520) 574-4247

✉ tucsonsales@westernstatesmetalroofing.com

Texas: 15023 County Rd 545, Nevada, TX 75173

☎ (972) 843-4343

✉ texas-sales@westernstatesmetalroofing.com

Washington: 3610 N. Barker Rd. STE C Spokane Valley, WA 99027

☎ (509) 418-2833

✉ washington-wsmr@westernstatesmetalroofing.com



www.facebook.com/westernstatesmetalroofing/



www.instagram.com/westernstatesmetalroofing/



www.twitter.com/weststatesmetal



www.youtube.com/westernstatesmetalroofing



www.linkedin.com/company/western-states-metal-roofing



www.pinterest.com/westernstatesmetalroofing/



www.houzz.com/pro/raynaann/western-states-metal-roofing