



Finishes You've Never Seen Before®

WESTERN STATES METAL ROOFING

(877) 787-5467 • WESTERNSTATESMETALROOFING.COM

NARROW GROOVE

INSTALLATION GUIDE WITH TRIM, FLASHINGS AND DETAILS

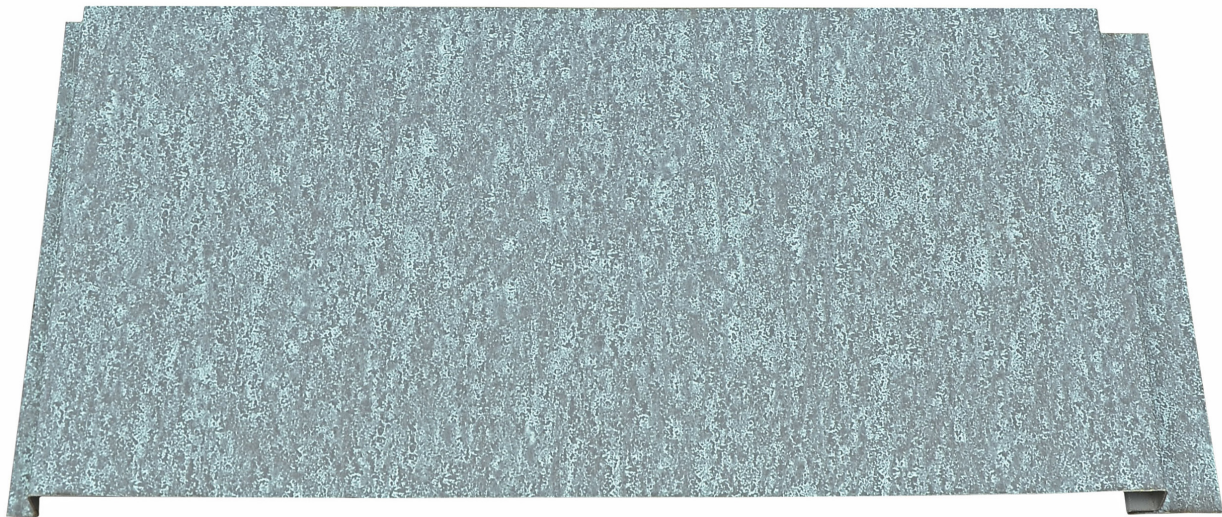

Phoenix: 901 W Watkins St., Phoenix, AZ 85007
☎ (602) 495-0048
✉ sales@westernstatesmetalroofing.com

Tucson: 4975 E. Drexel Rd., Tucson, AZ 85706
☎ (520) 574-4247
✉ tucsonsales@westernstatesmetalroofing.com



Narrow Groove
Installation, Flashings & Shop Drawing Detail Guide

Table of Contents

Section	Page
Notes to Designer /Installers.....	1
Fastener Placement and Selection.....	2-3
T-Groove Panel Options.....	4-7
T-Groove Profile Reveals.....	8-11
T-Groove Stiffening Options.....	12-16
T-Groove Perforated Panel.....	17
Key Wall Plan	18
Key Flashing / Trims	19-20
Soffit End Splice Detail	21
Wall Splice Detail	22
Soffit End Wall Detail	23
Alternate Soffit End wall.....	24
Soffit to Wall Drip Detail.....	25
Horizontal Siding End Wall Detail.....	26
Vertical Siding End Wall Detail.....	27
Parapet Wall Detail	28
Splice/ Sill Detail.....	29
Base Trim Detail.....	30
Door/ Window Sill & Head Detail.....	31
Door / Window Jamb Detail.....	32
Door / Window Sill Detail.....	33
Outside Corner Detail	34
Inside Corner Detail.....	35
Custom Outside Corner Detail.....	36

Section	Page
Custom Inside Corner Detail.....	37
Soffit to Wall Horizontal Detail	38
Parapet Wall Horizontal Detail.....	39
Splice /Sill Horizontal Detail	40
Base Horizontal Detail.....	41
Window/ Door Head Horizontal Detail.....	42
Window/ Door Jamb Horizontal Detail.....	43
Window/Door Sill Horizontal Detail.....	44
Outside corner Horizontal Detail.....	45
Inside Corner Horizontal Detail.....	46
Notes.....	47
Custom Trim	48
Design Considerations.....	49
Contact Information.....	50

Narrow Grove

Installation, Flashings & Shop Drawing Detail Guide

Notes to Designer and Installers

The details contained in this guide are proven industry details and are intended to be used as a design aid and installation guide. It does not depict all situations that may be encountered on all projects. Modifications are the responsibility of the designer/ owner/ installer. Consideration should be given for Fit for Purpose, Building use, Climate conditions such as temperature, snow, wind, and moisture, Governing Building Codes, and Maintenance. It is highly recommended that all trims and flashings be of the same material as the panels (metal, gauge, finish) to ensure long term performance and durability. Where possible, flashing edges should be hemmed to strengthen the edge and protect the cut edge from exposure.

Framing and Substrates

T-Groove® panels are used over all type of substrates like Steel Framing, open purlins, spaced sheathing, and wood surface such as plywood. Most details in this guide are shown with panels attached to Solid Wood Decking.

Note on Underlayment

Not all conditions require an underlayment, However metal siding is susceptible to Condensation and it is recommended that an appropriate underlayment be use on all wood substrates to protect the structure during installation. For added protection from rain and snow, it is recommended to use Sharkskin® Ultra and Sharkskin® Ultra SA.

Technical Assistance

Contact your WSDI sales or technical representative for any additional information or assistance.

Oil Canning

Oil canning is a condition common with flat metal surfaces. This waviness is caused by steel mill tolerances, forming, variations in the structures surfaces, and hardness of the steel. Measures are taken at the roll forming process, like profile design, steel gauge, corrective leveling, to minimize the effects of oil canning. Oil Canning is a Characteristic of steel and can not be eliminated totally and therefore is not reason for rejection of the panels.

Job Site Storage

While waiting to be installed on the job site, Storage of panels, trim crates, and flat sheet should be sloped in order to allow for proper moisture run off. One end should be elevated so as not to allow ponding of water on the metal surface. When using tarps for protection, proper ventilation should be provided to prevent condensation. Moisture or condensation that is trapped inside a bundle can lead to white rust on sheeting.

References

For other installation techniques and details, The Sheet Metal and Air Conditioning Contractors National Association Inc. (SMACNA) and NRCA manuals are great resource for working with sheet metal.

Narrow Grove

Installation, Flashings & Shop Drawing Detail Guide

Fastener Selection

Notes to Installers:

Fastener Selection will vary depending on type and thickness of substrate.
Design Calculations for clip spacing should be completed by the design engineer.
The use of Butyl tape mastic, Butyl sealants and Curing Sealants is always recommended to insure weather tight installation.
Panels and flashings should never be installed in contact with dissimilar metals.
Use only those flashings and accessories designed for use with this panel.
Panel clip attachment screws must be long enough to fully penetrate through roof deck substrate or penetrate solid lumber at least one inch.

Exposed Trim Fasteners should have sealing washers and be coated to provide protection against corrosion.
Screws must be properly driven to ensure holding strength and proper seal. (see diagram)
Recommended drill speed is 2000rpm. Improper setting of drill speed can lead to snapping of screw heads.
Pre drilling of screw holes may be necessary with heavy gauge metals.

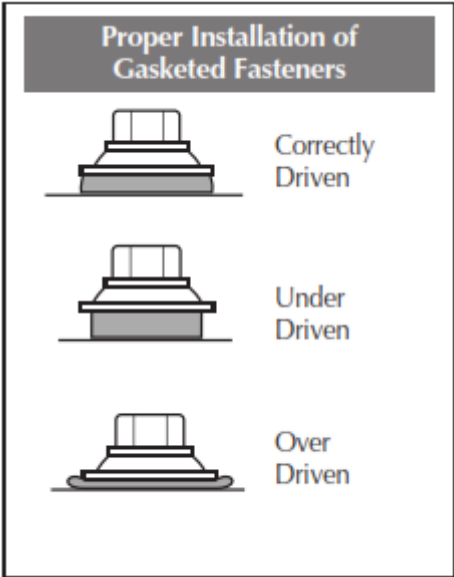

Narrow Grove

Installation, Flashings & Shop Drawing Detail Guide

Fastener Selection

Description

Application

14 x 7/8" Lap Self tap
14 x 7/8 Lap Stainless

Used to attach Trims .
Stainless to be used with
A606-4 Steel

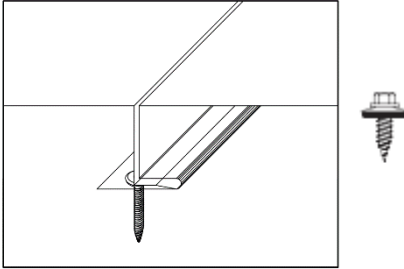

#10-12 x1" Pancake head
Wood
#10-12 x 1" SD PH Self Driller
Steel

Used to attach Panel clips.
Used to secure trims to
substrates. Also available in
Stainless Steel.



1/8" Stainless Rivets

Used for Trim to Trim
attachment or trim to wall
panels.



Stainless Screws
#10 x1 x1/4" Wood Drillers
#10 x 1.5 x 1/4"
#10 x 2" x 1/4"

Used for panel attachment
for panels made with
A606-4 Steel



The table above shows the panel fasteners provided by WSD. Special order screws are available.

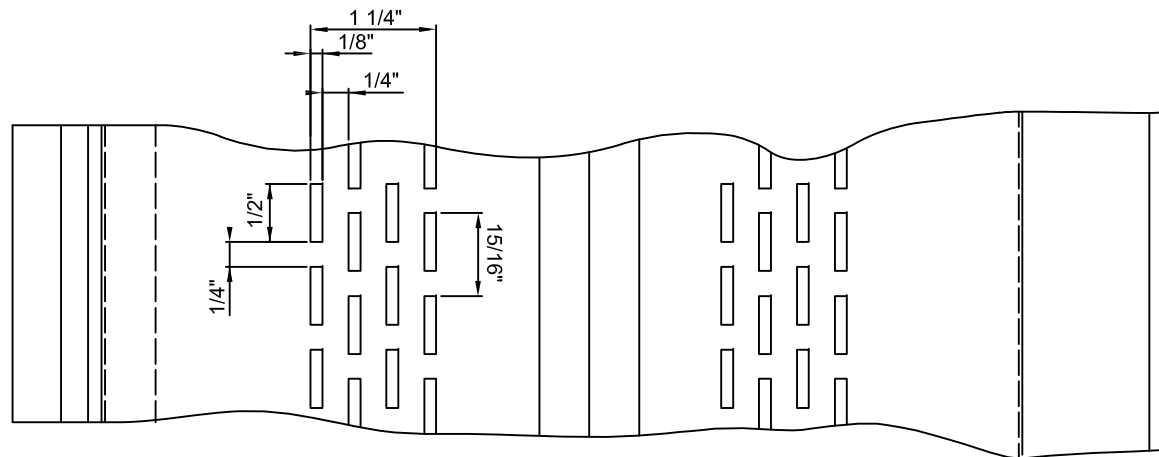
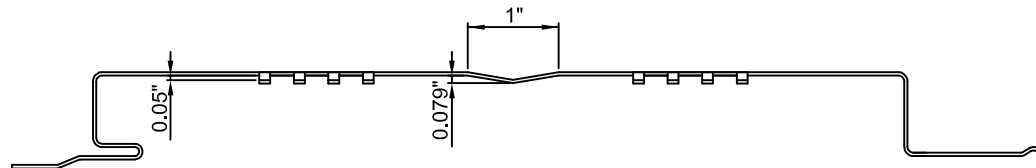
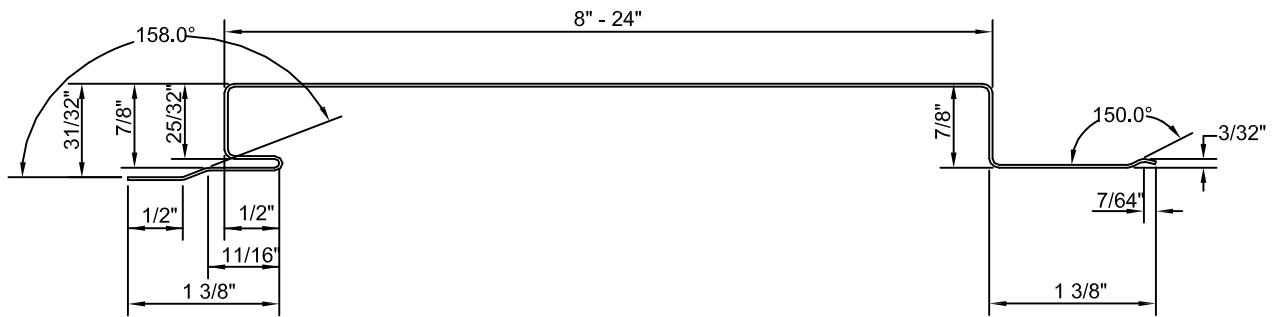

NOTES:

1. OPTIONAL RIB OR STRIATIONS AVAILABLE
2. PERFORATED VENTING AVAILABLE
3. EVERY LINEAR FOOT OF SINGLE ROW OF 1.25" PERFORATED SOFFIT PANEL EQUALS TO 15 SQUARE INCHES OF FREE AIR FLOW
4. EVERY LINEAR FOOT OF DOUBLE ROW OF 1.25" PERFORATED SOFFIT PANEL EQUALS TO 30 SQUARE INCHES OF FREE AIR FLOW
5. 12" MIN. PANEL WIDTH REQUIRED FOR DOUBLE PERFORMANCE PATTERN.



Metal Roofing Manufacturer. No Installation Services Available.

WESTERN STATES METAL ROOFING

Finishes You've Never Seen Before®

TOLERANCES
WIDTH = .25"
LENGTH = .50"
HEIGHT = .125"

PART NAME		
NARROW GROOVE		
MATERIAL	SHEET	REVISION
PAINTED STEEL / PAINTED ALUMINUM / COPPER	1 OF 1	1

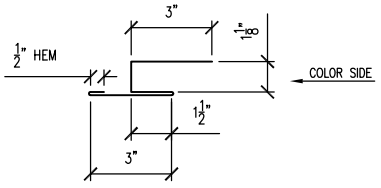
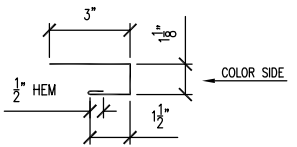
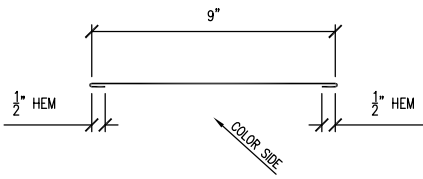
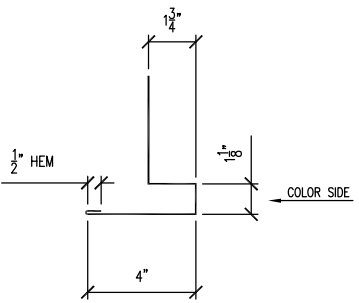
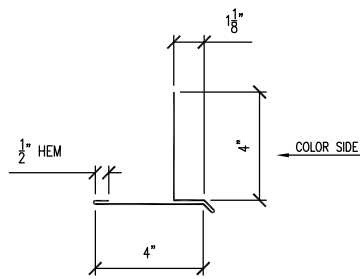
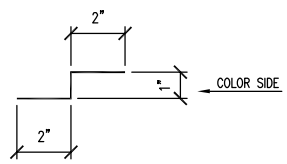
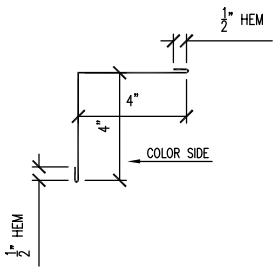
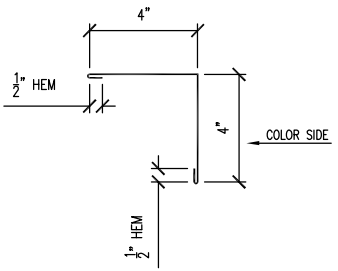
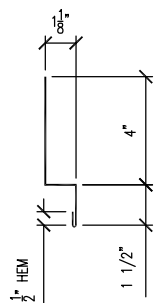
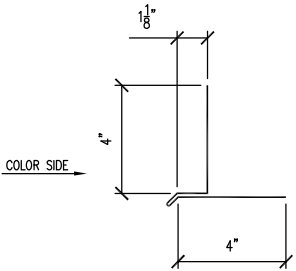
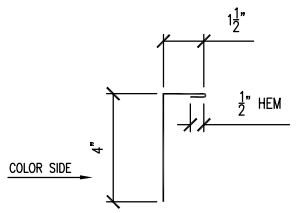
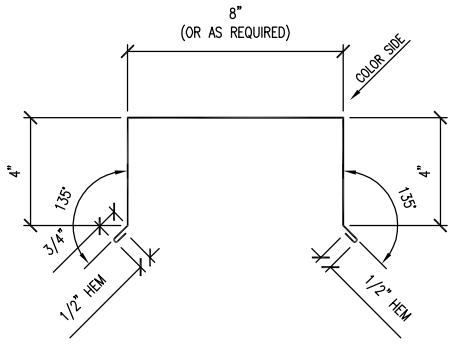
<p>END SPLICE WS-500</p> 	<p>C METAL (J-TRIM) WS-501</p> 	<p>REVEAL FLASHING WS-502</p> 	<p>SILL DRIP TRIM WS-504</p> 
<p>ALTERNATE SILL DRIP TRIM WS-505</p> 	<p>Z METAL TRIM WS-506</p> 	<p>INSIDE CORNER TRIM WS-507</p> 	<p>OUTSIDE CORNER TRIM WS-508</p> 
<p>TRANSITION/SILL TRIM WS-509</p> 	<p>DOOR/WINDOW HEAD TRIM WS-510</p> 	<p>DOOR/WINDOW JAMB TRIM WS-511</p> 	<p>PARAPET CAP WS-512</p> 

Western States Metal Roofing

901 W. Watkins St.
 Phoenix, AZ 85007
www.MetalForRoofing.com
www.RustedRoofing.com
www.MetalDeck.com

Phone: (602) 495-0048
 Fax: (602) 261-7726
 877-PURLINS (787-5467)

STANDARD TRIM			
		A	5/15/22
NARROW GROOVE		REV:	DATE:
		DETAIL #:	TG-WSD-ST5

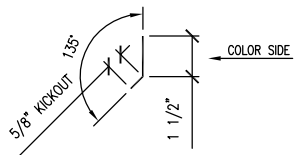
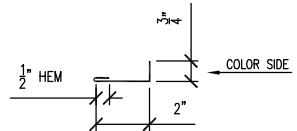
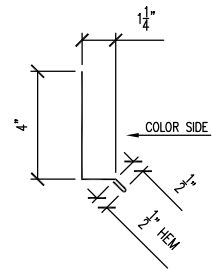
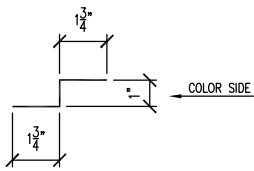
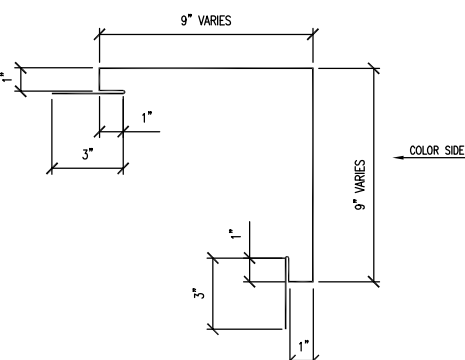
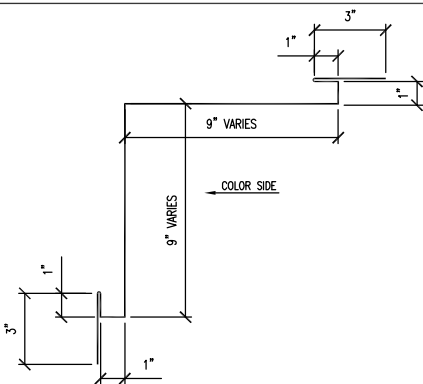
<p>TRIM CLEAT WS-513</p> 	<p>ALTERNATE WALL TRIM WS-514</p> 	<p>BASE TRIM WS-515</p> 	<p>Z METAL TRIM (SMALL) WS-516</p> 
<p>CUSTOM OUTSIDE CORNER WS-517</p> 	<p>CUSTOM INSIDE CORNER WS-518</p> 		

Western States Metal Roofing

901 W. Watkins St.
 Phoenix, AZ 85007
www.MetalForRoofing.com
www.RustedRoofing.com
www.MetalDeck.com

Phone: (602) 495-0048
 Fax: (602) 261-7726
 877-PURLINS (787-5467)

STANDARD TRIM			
		A	5/15/22
PANEL TYPE: NARROW GROOVE		REV:	DATE:
		DETAIL #: TG-WSD-ST6	

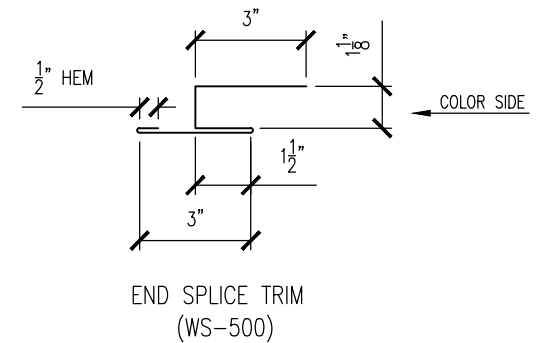
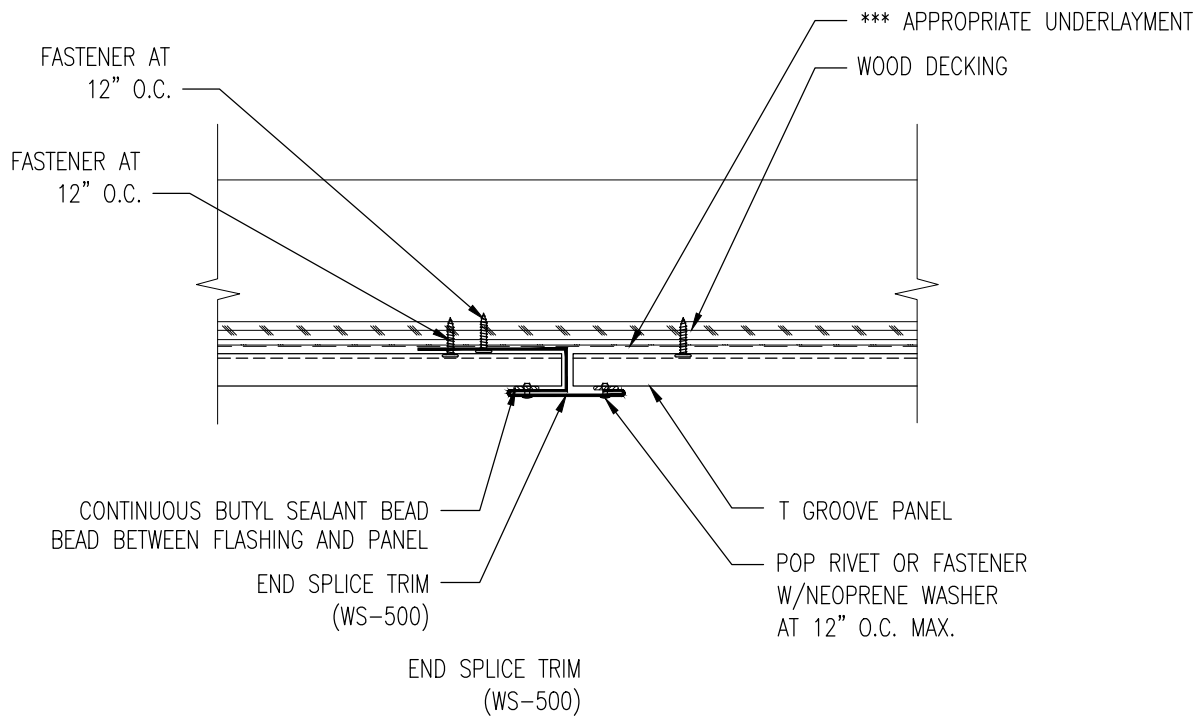

*** WSMR RECOMMENDS SHARKSKIN®ULTRA OR SHARKSKIN®ULTRA SA

Western States Metal Roofing

901 W. Watkins St.
 Phoenix, AZ 85007
www.MetalForRoofing.com
www.RustedRoofing.com
www.MetalDeck.com

Phone: (602) 495-0048
 Fax: (602) 261-7726
 877-PURLINS (787-5467)

GAUGE: _____	COLOR: _____		
LENGTH: _____	FINISH: _____		
MATERIAL: _____			
SOFFIT END SPLICE DETAIL		A	5/15/22
		REV:	DATE:
NARROW GROOVE		DETAIL #:	
		TG-WSD-S1	

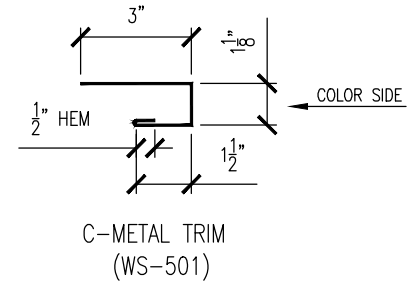
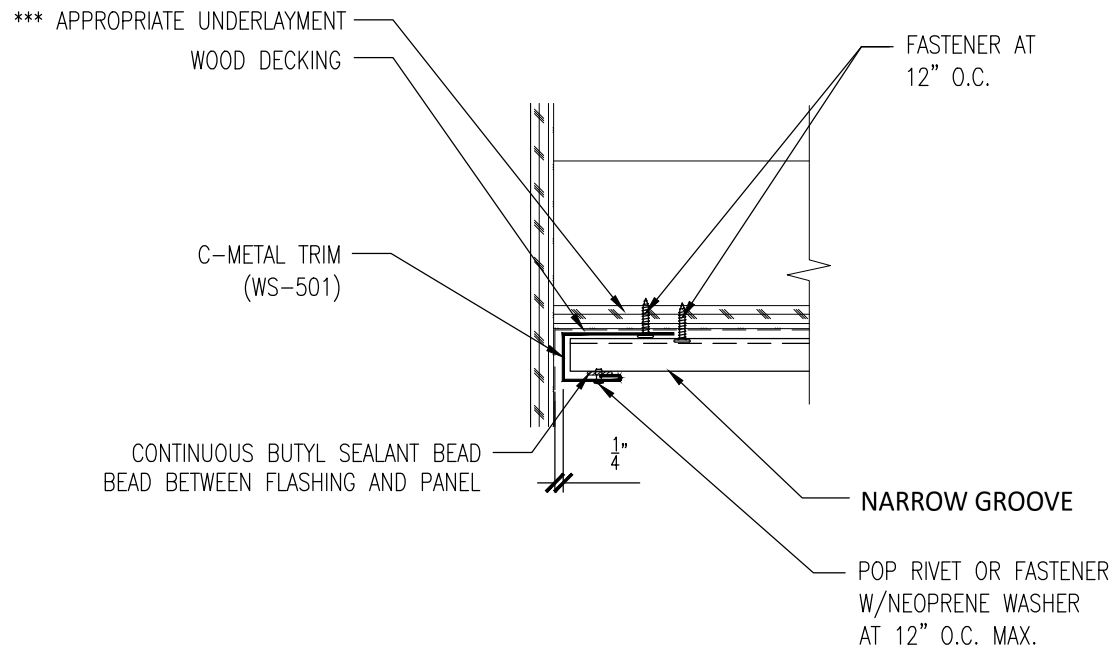

*** WSMR RECOMMENDS SHARKSKIN[®] ULTRA OR SHARKSKIN[®] ULTRA SA

Western States Metal Roofing

901 W. Watkins St.
 Phoenix, AZ 85007
www.MetalForRoofing.com
www.RustedRoofing.com
www.MetalDeck.com

Phone: (602) 495-0048
 Fax: (602) 261-7726
 877-PURLINS (787-5467)

GAUGE: _____	COLOR: _____	
LENGTH: _____	FINISH: _____	
MATERIAL: _____		
SOFFIT END WALL DETAIL	A	5/15/22
	REV:	DATE:
PANEL TYPE: NARROW GROOVE	DETAIL #: TG-WSD-S3	

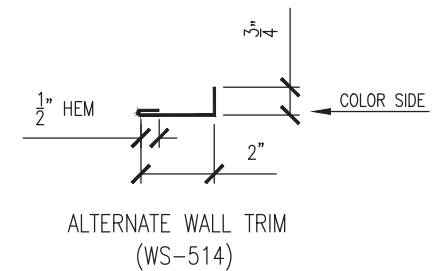
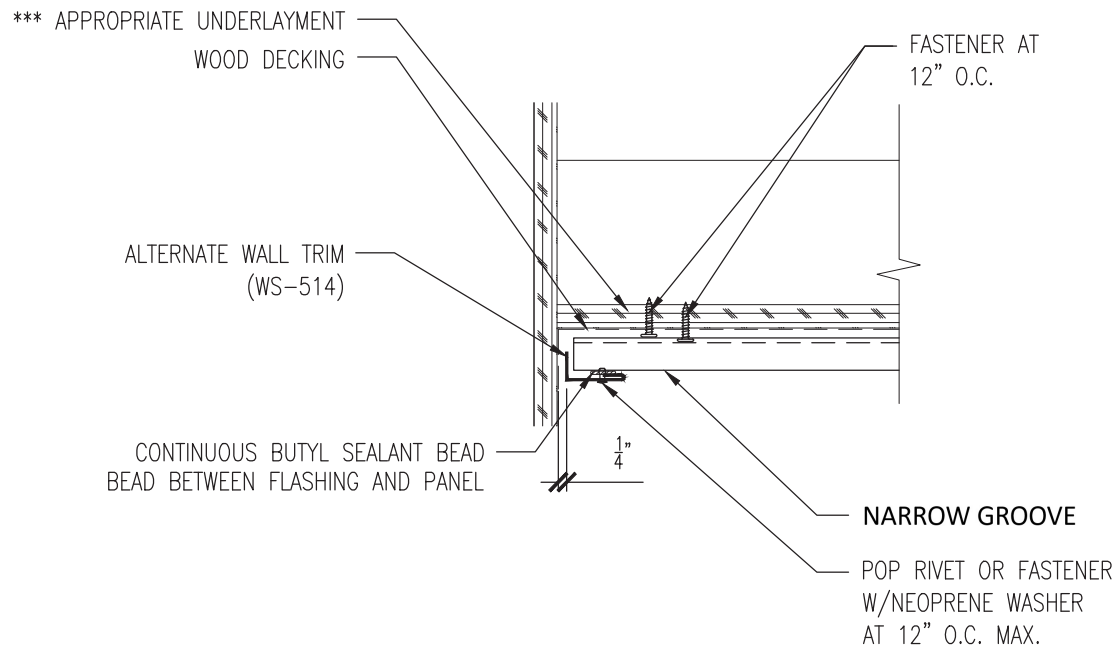

*** WSMR RECOMMENDS SHARKSKIN® ULTRA OR SHARKSKIN® ULTRA SA

Western States Metal Roofing

901 W. Watkins St.
 Phoenix, AZ 85007
www.MetalForRoofing.com
www.RustedRoofing.com
www.MetalDeck.com

Phone: (602) 495-0048
 Fax: (602) 261-7726
 877-PURLINS (787-5467)

GAUGE: _____		COLOR: _____	
LENGTH: _____		FINISH: _____	
MATERIAL: _____			
ALTERNATE SOFFIT END WALL DETAIL			
		A	5/15/22
PANEL TYPE: NARROW GROOVE		REV:	DATE:
		DETAIL #: TG-WSD-SW4	

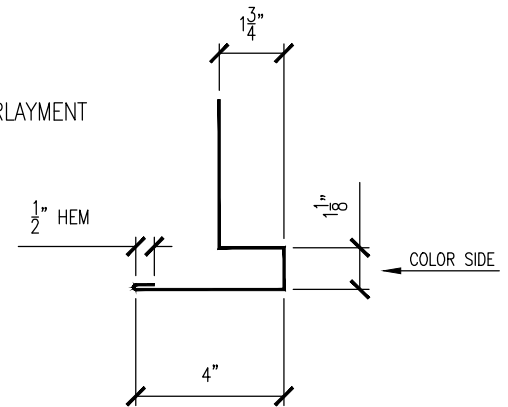
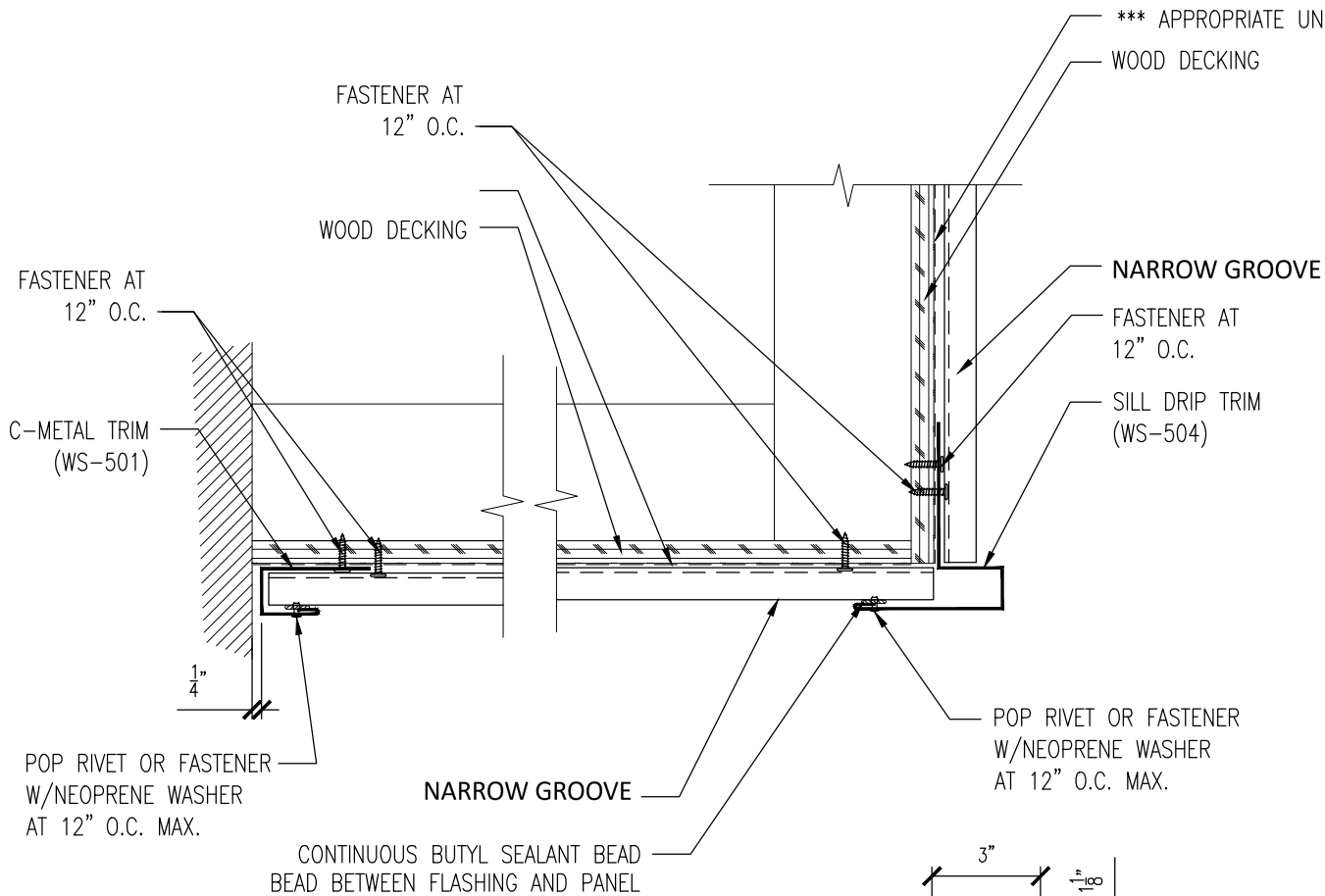

SILL DRIP TRIM (WS-504)

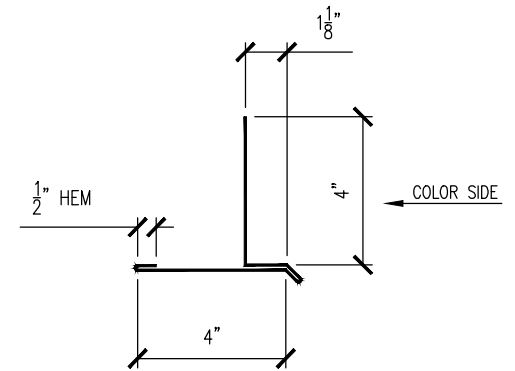

ALTERNATE SILL DRIP TRIM (WS-505)

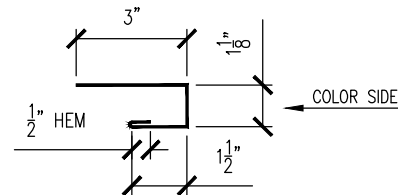

C-METAL TRIM (WS-501)

*** WSMR RECOMMENDS SHARKSKIN® ULTRA OR SHARKSKIN® ULTRA SA

GAUGE: _____	COLOR: _____
LENGTH: _____	FINISH: _____
MATERIAL: _____	

Western States Metal Roofing

901 W. Watkins St.
 Phoenix, AZ 85007
 www.MetalForRoofing.com
 www.RustedRoofing.com
 www.MetalDeck.com

Phone: (602) 495-0048
 Fax: (602) 261-7726
 877-PURLINS (787-5467)

SOFFIT TO WALL DRIP DETAIL	A	5/15/22
	REV:	DATE:
PANEL TYPE: NARROW GROOVE	DETAIL #: TG-WSD-SW5	

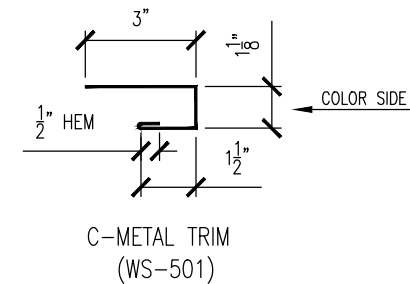
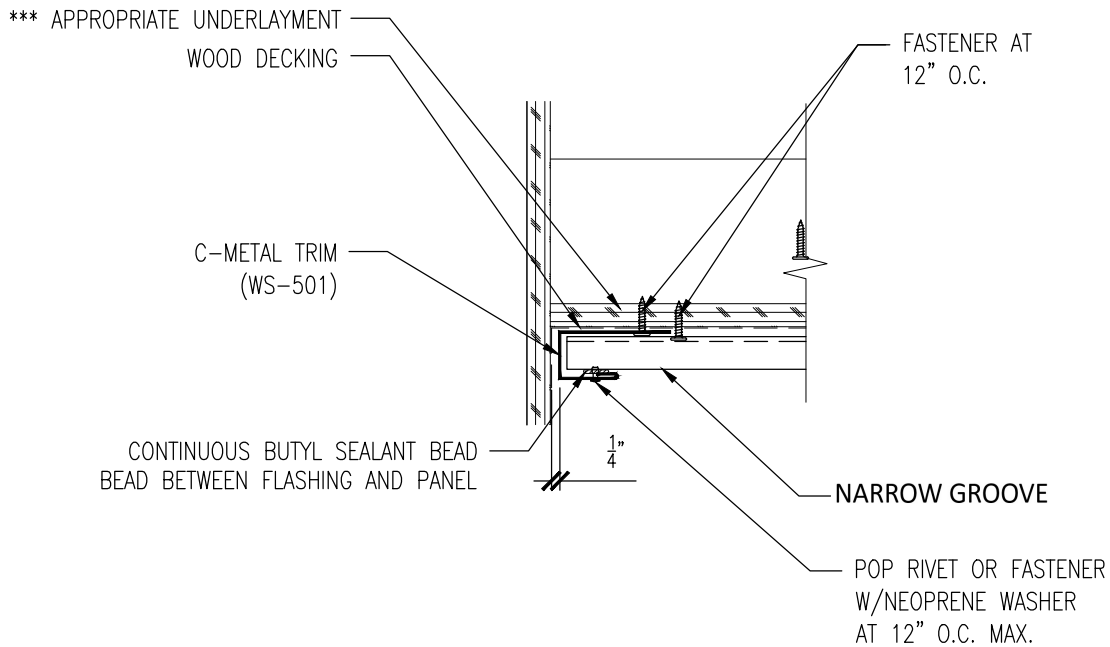

*** WSMR RECOMMENDS SHARKSKIN[®] ULTRA OR SHARKSKIN[®] ULTRA SA

GAUGE: _____	COLOR: _____
LENGTH: _____	FINISH: _____
MATERIAL: _____	

Western States Metal Roofing

901 W. Watkins St.
 Phoenix, AZ 85007
www.MetalForRoofing.com
www.RustedRoofing.com
www.MetalDeck.com

Phone: (602) 495-0048
 Fax: (602) 261-7726
 877-PURLINS (787-5467)

HORIZONTAL SIDING END WALL DETAIL		
	A	5/15/22
PANEL TYPE: NARROW GROOVE	REV:	DATE:
	DETAIL #: TG-WSD-W6	

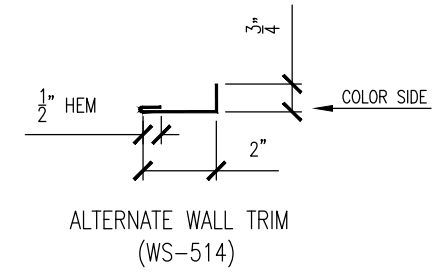
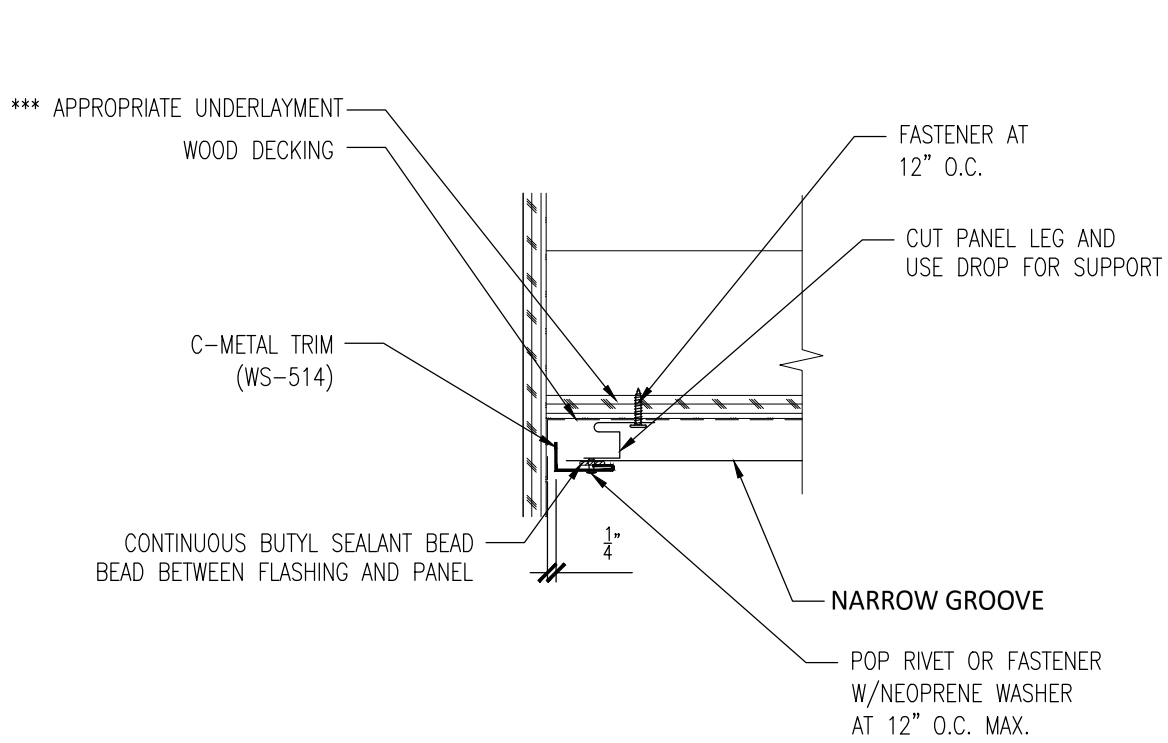

*** WSMR RECOMMENDS SHARKSKIN®ULTRA OR SHARKSKIN®ULTRA SA

Western States Metal Roofing

901 W. Watkins St.
 Phoenix, AZ 85007
www.MetalForRoofing.com
www.RustedRoofing.com
www.MetalDeck.com

Phone: (602) 495-0048
 Fax: (602) 261-7726
 877-PURLINS (787-5467)

GAUGE: _____		COLOR: _____	
LENGTH: _____		FINISH: _____	
MATERIAL: _____			
VERTICAL SIDING END WALL DETAIL			
		A	5/15/22
PANEL TYPE: NARROW GROOVE		REV:	DATE:
		DETAIL #: TG-WSD-SW7	

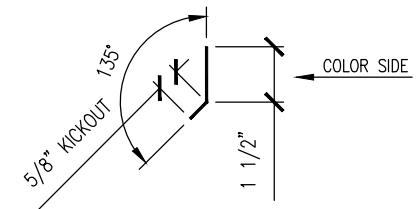
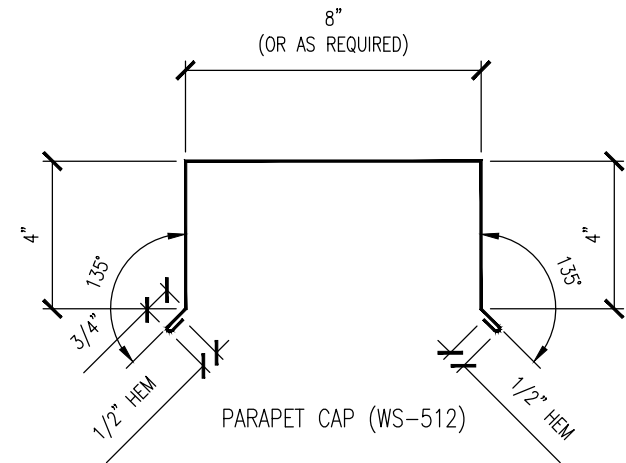
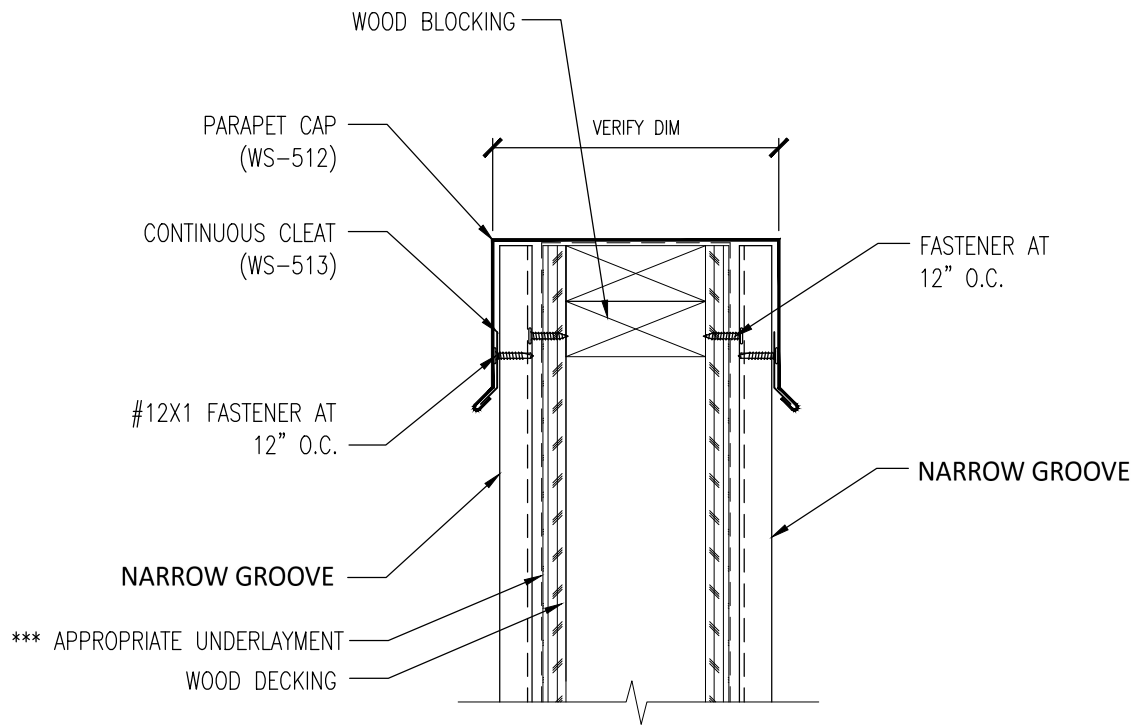

CONTINUOUS CLEAT (WS-513)

VERTICAL WALL INSTALL

*** WSMR RECOMMENDS SHARKSKIN®ULTRA OR SHARKSKIN®ULTRA SA

Western States Metal Roofing

901 W. Watkins St.
 Phoenix, AZ 85007
 www.MetalForRoofing.com
 www.RustedRoofing.com
 www.MetalDeck.com

Phone: (602) 495-0048
 Fax: (602) 261-7726
 877-PURLINS (787-5467)

GAUGE: _____		COLOR: _____	
LENGTH: _____		FINISH: _____	
MATERIAL: _____			
PARAPET WALL DETAIL			
		A	5/15/22
PANEL TYPE: NARROW GROOVE		REV:	DATE:
		DETAIL #: TG-WSD-W8	

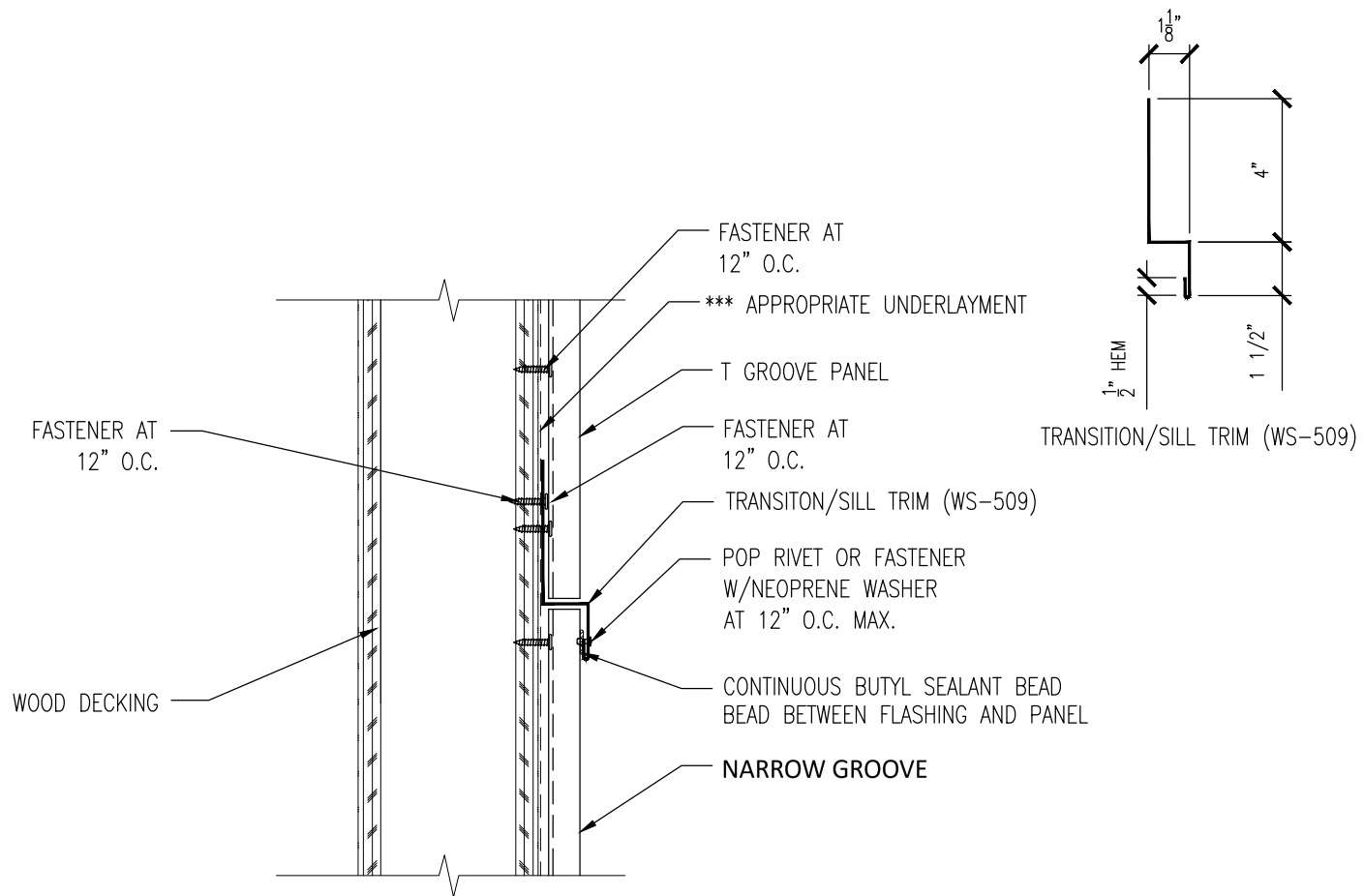

VERTICAL WALL INSTALL

*** WSMR RECOMMENDS SHARKSKIN®ULTRA OR SHARKSKIN®ULTRA SA

GAUGE: _____	COLOR: _____		
LENGTH: _____	FINISH: _____		
MATERIAL: _____			
SPLICE/SILL DETAIL		A	5/15/22
		REV:	DATE:
PANEL TYPE: NARROW GROOVE	DETAIL #: TG-WSD-W9		

Western States Metal Roofing

901 W. Watkins St.
Phoenix, AZ 85007
www.MetalForRoofing.com
www.RustedRoofing.com
www.MetalDeck.com

Phone: (602) 495-0048
Fax: (602) 261-7726
877-PURLINS (787-5467)

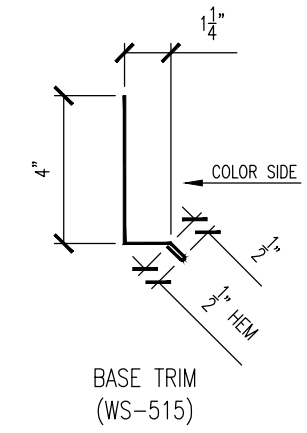
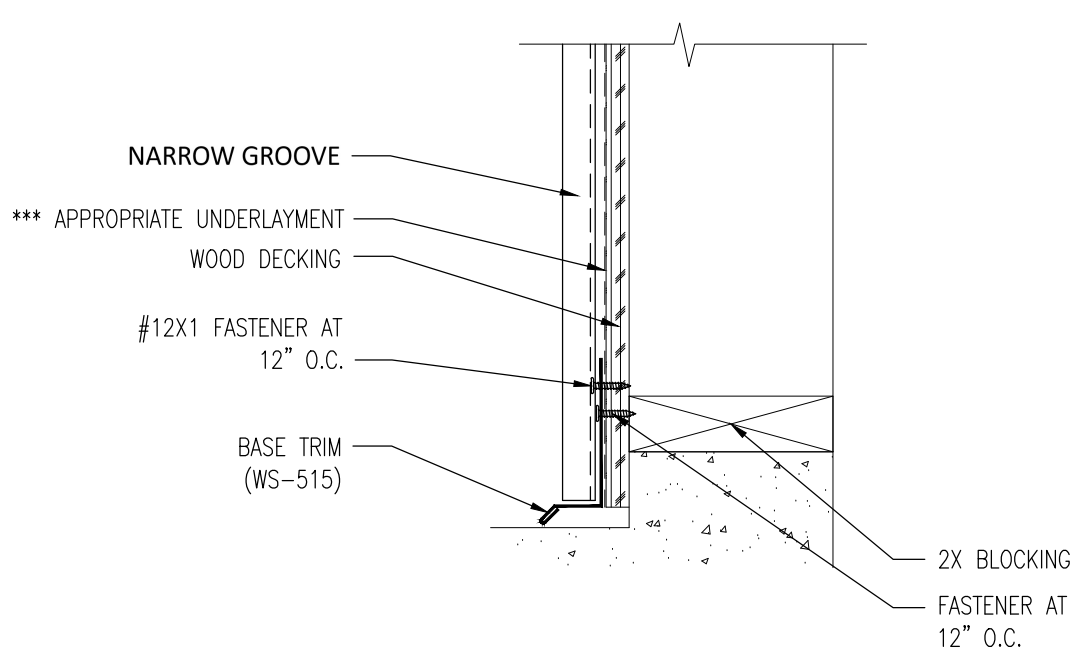

*** WSMR RECOMMENDS SHARKSKIN®ULTRA OR SHARKSKIN®ULTRA SA

GAUGE: _____	COLOR: _____
LENGTH: _____	FINISH: _____
MATERIAL: _____	

Western States Metal Roofing

901 W. Watkins St.
 Phoenix, AZ 85007
www.MetalForRoofing.com
www.RustedRoofing.com
www.MetalDeck.com

Phone: (602) 495-0048
 Fax: (602) 261-7726
 877-PURLINS (787-5467)

BASE DETAIL		
	A	5/15/22
PANEL TYPE: NARROW GROOVE	REV:	DATE:
	DETAIL #: TG-WSD-W10	

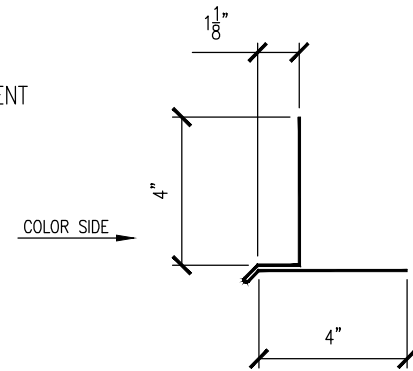
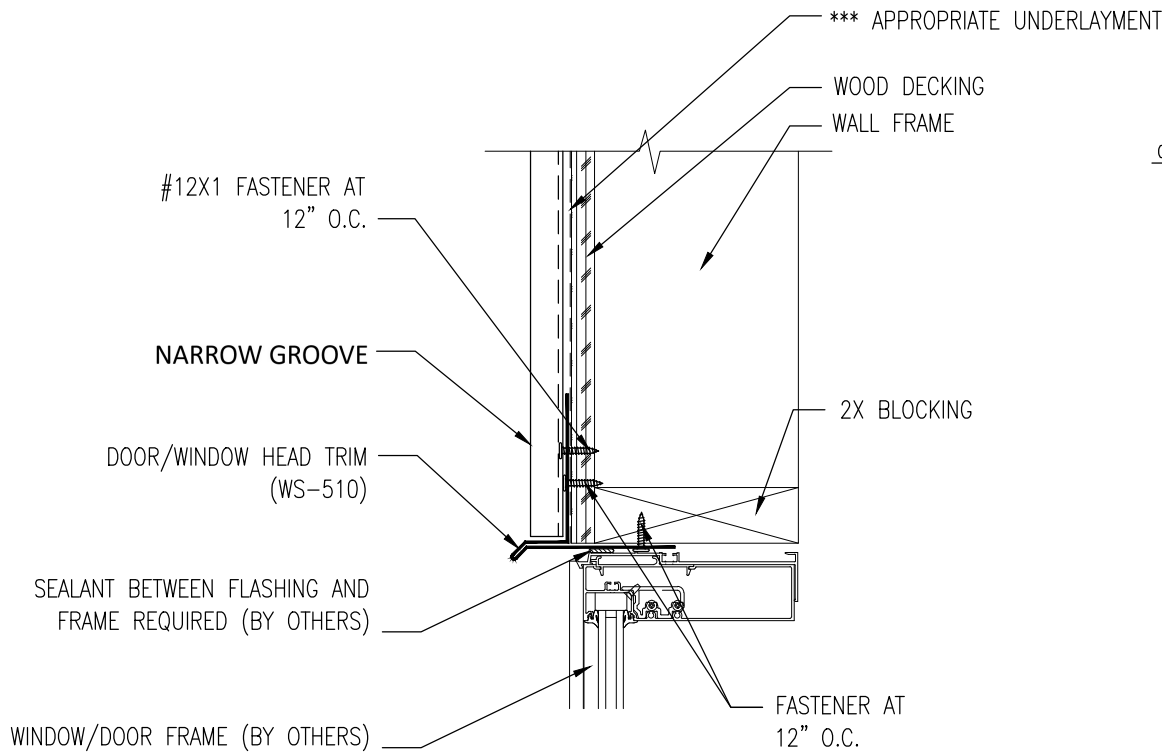

DOOR/WINDOW HEAD TRIM (WS-510)

VERTICAL WALL INSTALL

*** WSMR RECOMMENDS SHARKSKIN®ULTRA OR SHARKSKIN®ULTRA SA

GAUGE: _____	COLOR: _____	
LENGTH: _____	FINISH: _____	
MATERIAL: _____		
DOOR/WINDOW SILL AND HEAD DETAIL	A	5/15/22
	REV:	DATE:
PANEL TYPE: NARROW GROOVE	DETAIL #: TG-WSD-W11	

Western States Metal Roofing

901 W. Watkins St.
Phoenix, AZ 85007
www.MetalForRoofing.com
www.RustedRoofing.com
www.MetalDeck.com

Phone: (602) 495-0048
Fax: (602) 261-7726
877-PURLINS (787-5467)

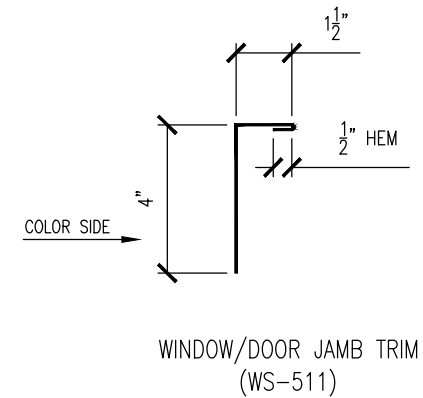
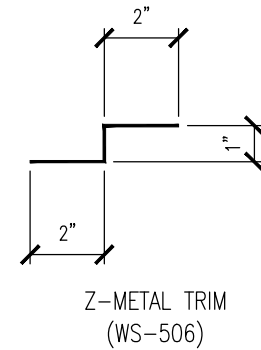
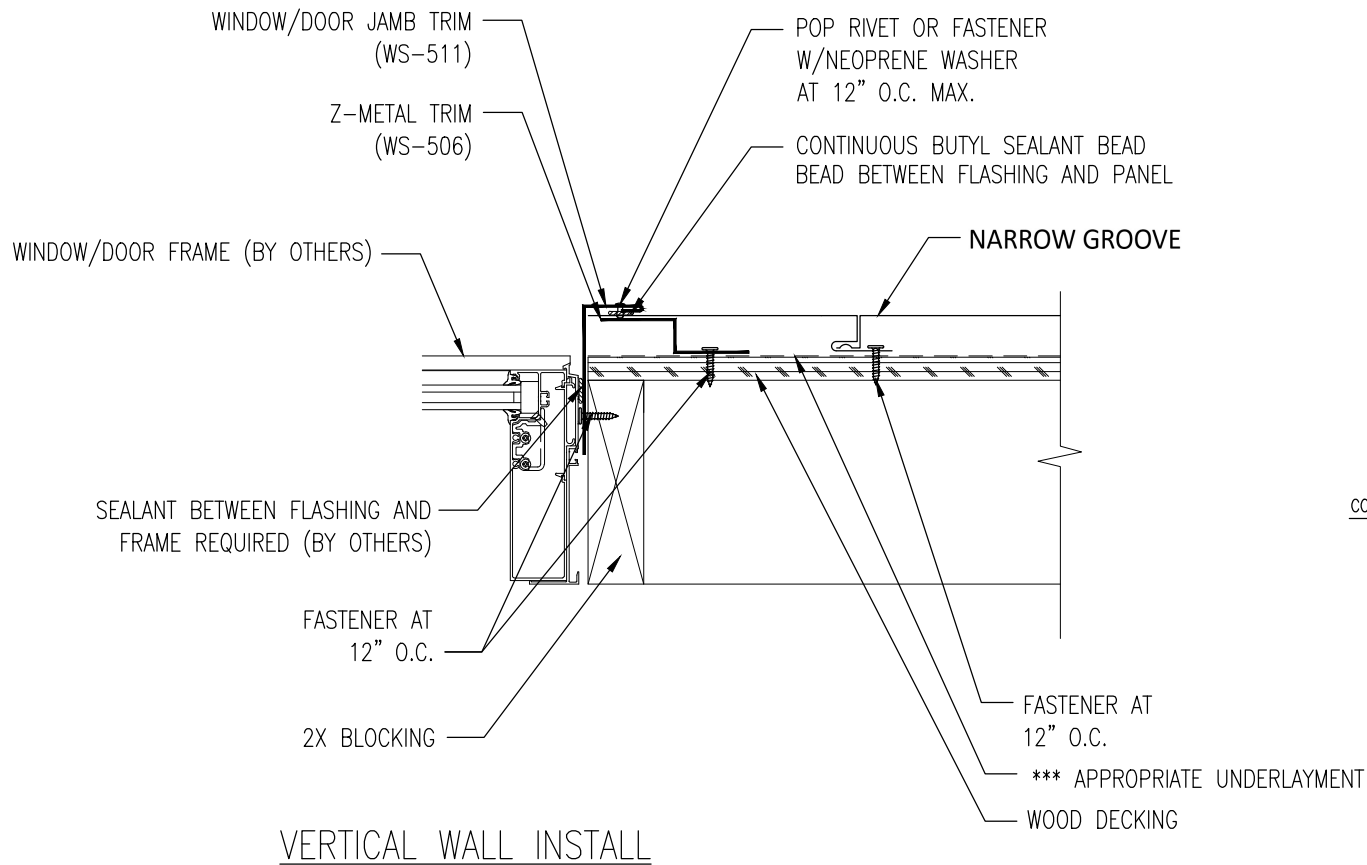

*** WSMR RECOMMENDS SHARKSKIN®ULTRA OR SHARKSKIN®ULTRA SA

Western States Metal Roofing

901 W. Watkins St.
 Phoenix, AZ 85007
www.MetalForRoofing.com
www.RustedRoofing.com
www.MetalDeck.com

Phone: (602) 495-0048
 Fax: (602) 261-7726
 877-PURLINS (787-5467)

GAUGE: _____		COLOR: _____	
LENGTH: _____		FINISH: _____	
MATERIAL: _____			
WINDOW/DOOR JAMB DETAIL			
		A	5/15/22
PANEL TYPE: NARROW GROOVE		REV:	DATE:
		DETAIL #: TG-WSD-W12	

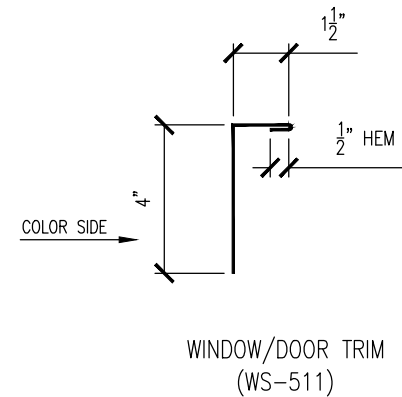
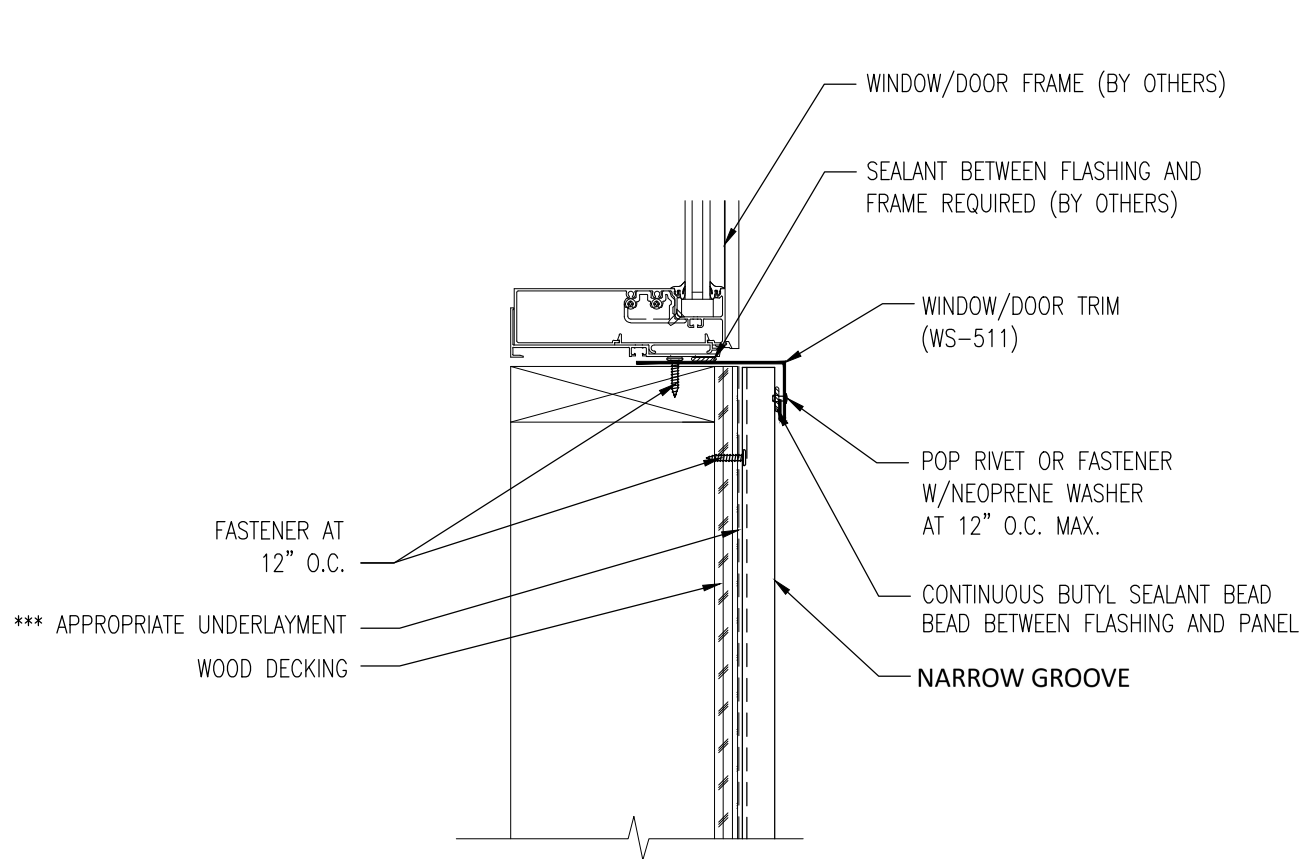

VERTICAL WALL INSTALL

*** WSMR RECOMMENDS SHARKSKIN[®]ULTRA OR SHARKSKIN[®]ULTRA SA

GAUGE: _____	COLOR: _____
LENGTH: _____	FINISH: _____
MATERIAL: _____	

Western States Metal Roofing

901 W. Watkins St.
 Phoenix, AZ 85007
www.MetalForRoofing.com
www.RustedRoofing.com
www.MetalDeck.com

Phone: (602) 495-0048
 Fax: (602) 261-7726
 877-PURLINS (787-5467)

DOOR/WINDOW SILL DETAIL		
	A	5/15/22
PANEL TYPE: NARROW GROOVE	REV:	DATE:
	DETAIL #: TG-WSD-W13	

NARROW GROOVE

FASTENER AT
12" O.C.

Z-METAL TRIM
(WS-506)

OUTSIDE CORNER
(WS-508)

Z-METAL TRIM-SMALL
(WS-516)

POP RIVET OR FASTENER
W/NEOPRENE WASHER
AT 12" O.C. MAX.

CONTINUOUS BUTYL SEALANT BEAD
BEAD BETWEEN FLASHING AND PANEL

NARROW GROOVE

FASTENER AT
12" O.C.

*** APPROPRIATE UNDERLAYMENT
WOOD DECKING

VERTICAL WALL INSTALL

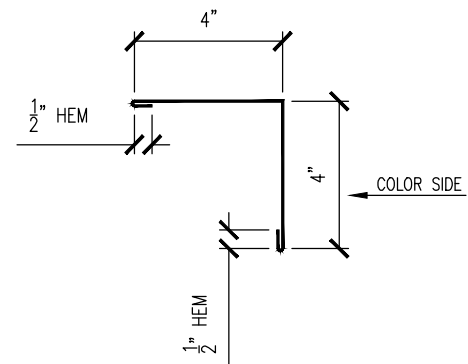

OUTSIDE CORNER
(WS-508)

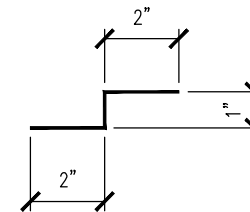

Z-METAL TRIM
(WS-506)

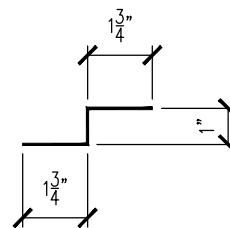

Z-METAL TRIM (SMALL)

*** WSMR RECOMMENDS SHARKSKIN® ULTRA OR SHARKSKIN® ULTRA SA (WS-516)

GAUGE: _____	COLOR: _____
LENGTH: _____	FINISH: _____
MATERIAL: _____	

Western States Metal Roofing

901 W. Watkins St.
Phoenix, AZ 85007
www.MetalForRoofing.com
www.RustedRoofing.com
www.MetalDeck.com

Phone: (602) 495-0048
Fax: (602) 261-7726
877-PURLINS (787-5467)

OUTSIDE CORNER DETAIL		
	A	5/15/22
PANEL TYPE: NARROW GROOVE	REV:	DATE:
	DETAIL #: TG-WSD-W14	

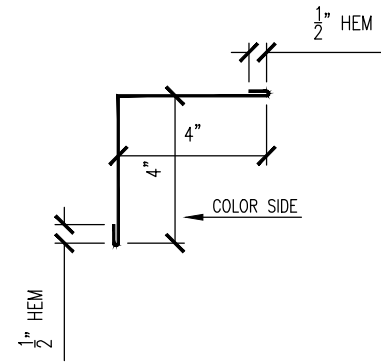
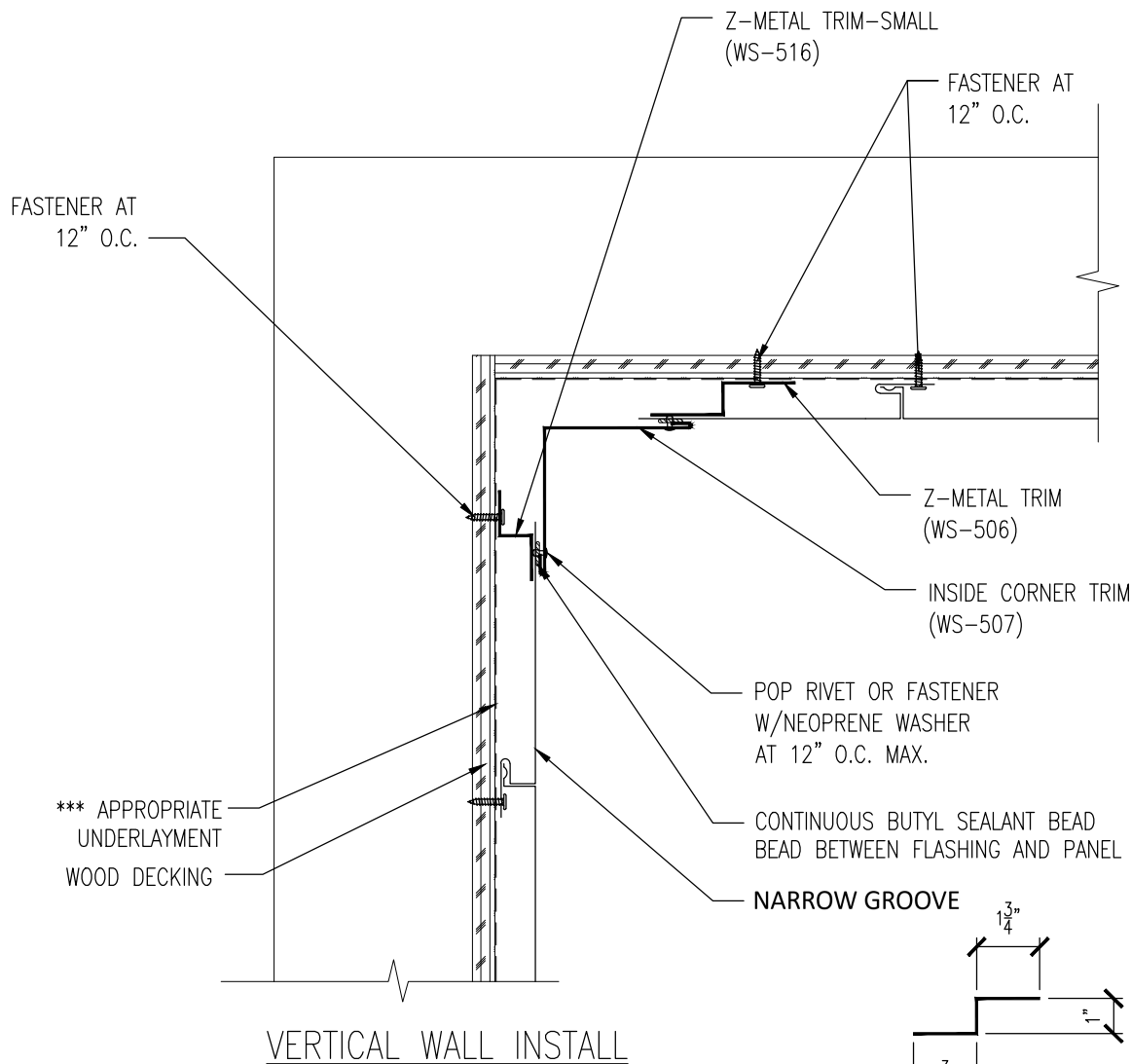

INSIDE CORNER TRIM (WS-507)

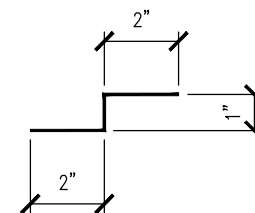

Z-METAL TRIM (WS-506)

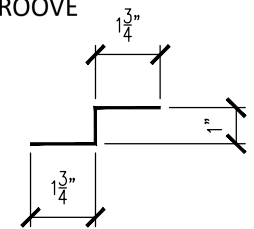

Z-METAL TRIM (SMALL) (WS-516)

*** WSMR RECOMMENDS SHARKSKIN®ULTRA OR SHARKSKIN®ULTRA SA

Western States Metal Roofing

901 W. Watkins St.
 Phoenix, AZ 85007
www.MetalForRoofing.com
www.RustedRoofing.com
www.MetalDeck.com

Phone: (602) 495-0048
 Fax: (602) 261-7726
 877-PURLINS (787-5467)

GAUGE: _____	COLOR: _____	
LENGTH: _____	FINISH: _____	
MATERIAL: _____		
INSIDE CORNER DETAIL	A	5/15/22
	REV:	DATE:
PANEL TYPE: NARROW GROOVE	DETAIL #: TG-WSD-W15	

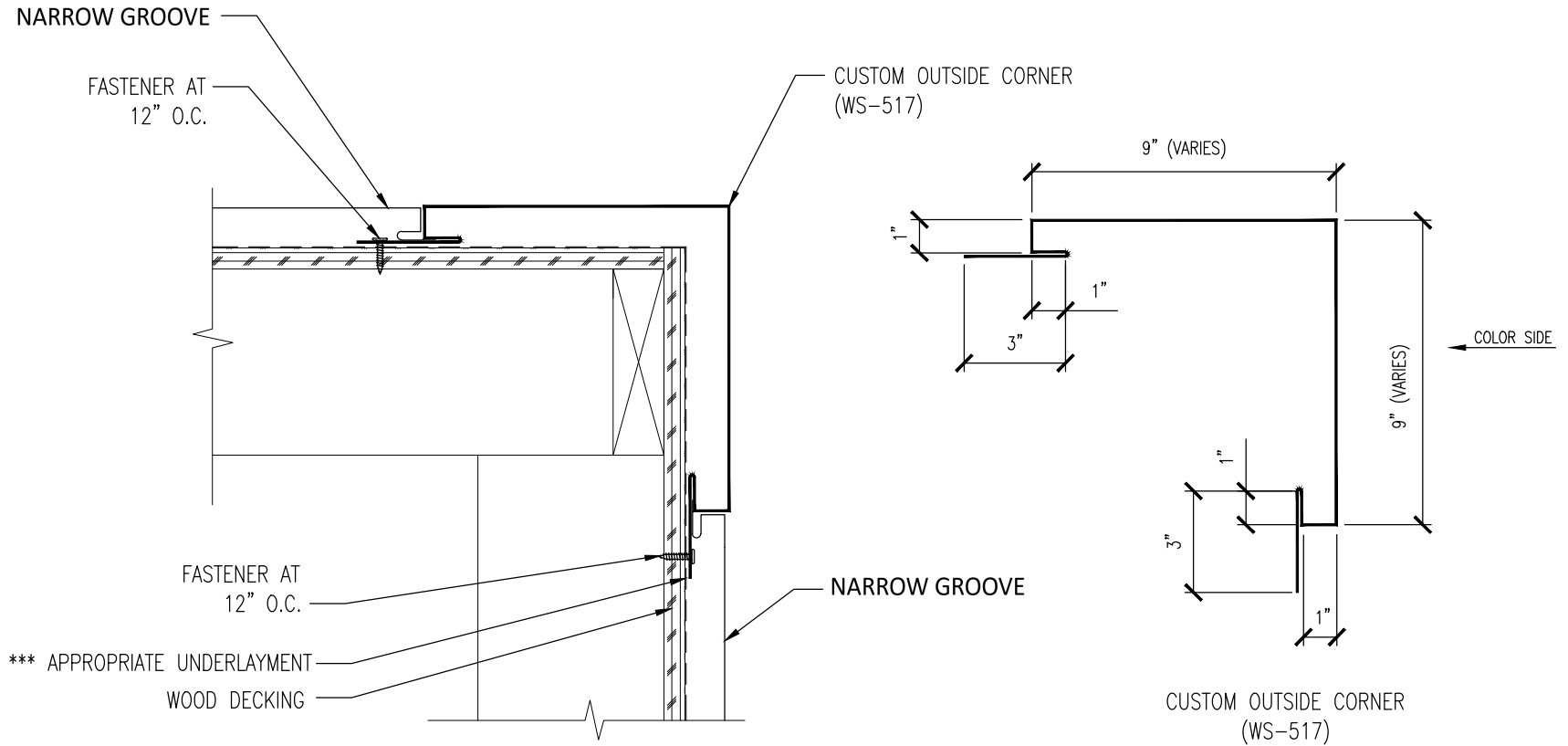

*** WSMR RECOMMENDS SHARKSKIN®ULTRA OR SHARKSKIN®ULTRA SA

Western States Metal Roofing

901 W. Watkins St.
 Phoenix, AZ 85007
www.MetalForRoofing.com
www.RustedRoofing.com
www.MetalDeck.com

Phone: (602) 495-0048
 Fax: (602) 261-7726
 877-PURLINS (787-5467)

GAUGE: _____	COLOR: _____
LENGTH: _____	FINISH: _____
MATERIAL: _____	
CUSTOM OUTSIDE CORNER DETAIL	
	A 5/15/22
	REV: DATE:
	DETAIL #: TG-WSD-W16
PANEL TYPE: NARROW GROOVE	

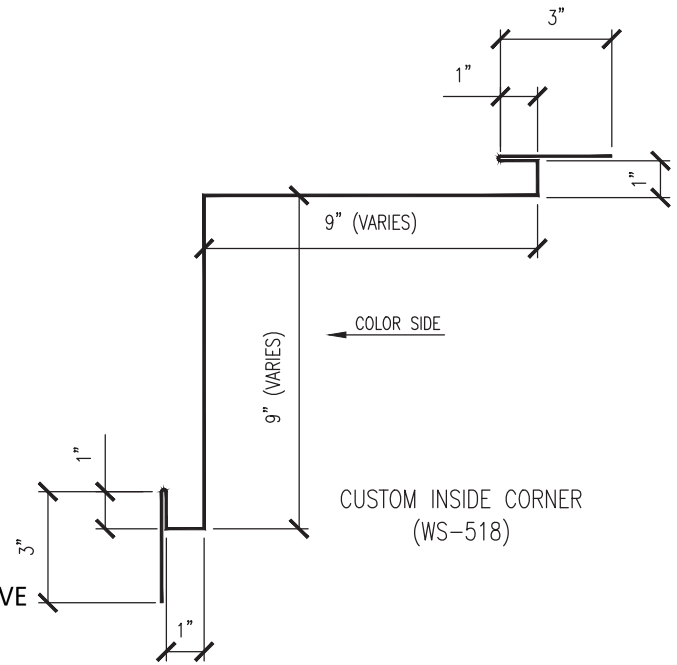
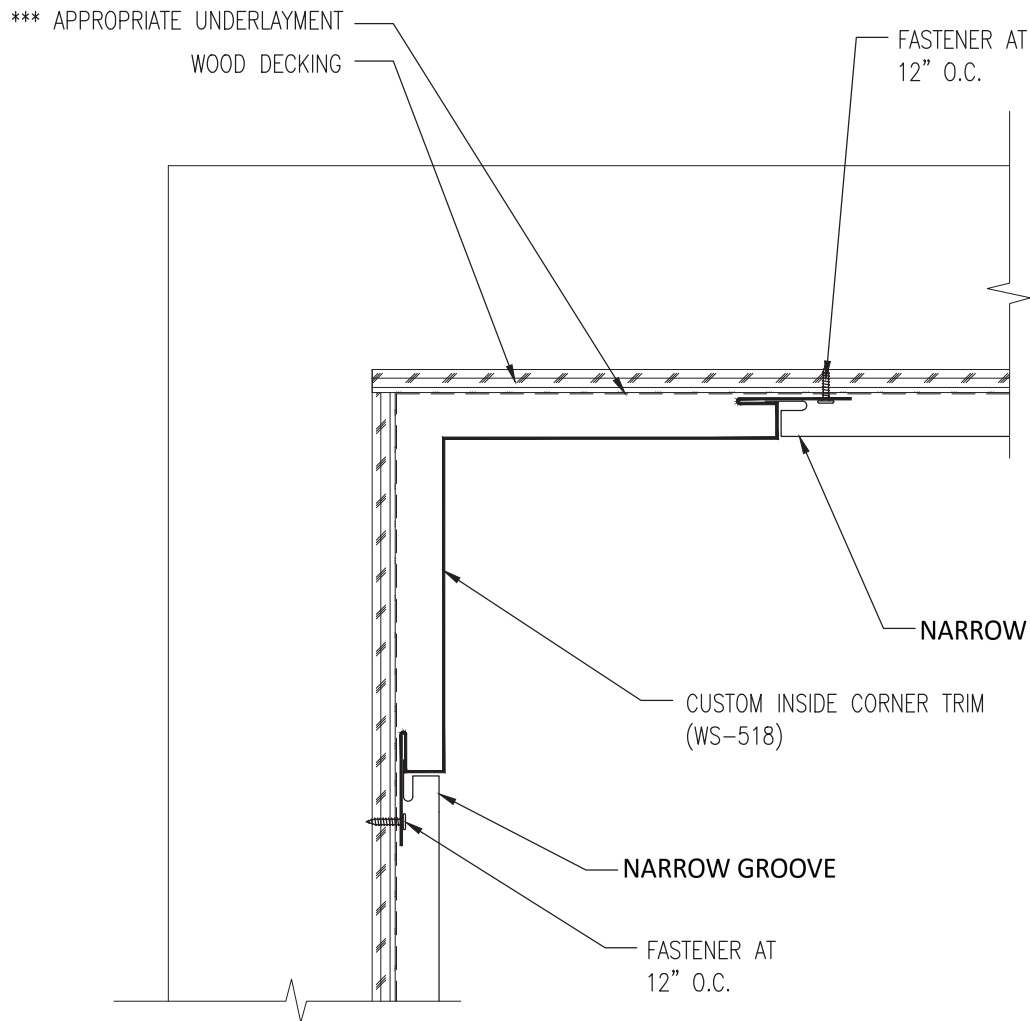

*** WSMR RECOMMENDS SHARKSKIN® ULTRA OR SHARKSKIN® ULTRA SA

GAUGE: _____	COLOR: _____
LENGTH: _____	FINISH: _____
MATERIAL: _____	

Western States Metal Roofing

901 W. Watkins St.
 Phoenix, AZ 85007
www.MetalForRoofing.com
www.RustedRoofing.com
www.MetalDeck.com

Phone: (602) 495-0048
 Fax: (602) 261-7726
 877-PURLINS (787-5467)

CUSTOM INSIDE CORNER DETAIL		
	A	5/15/22
PANEL TYPE: NARROW GROOVE	REV:	DATE:
	DETAIL #: TG-WSD-W17	

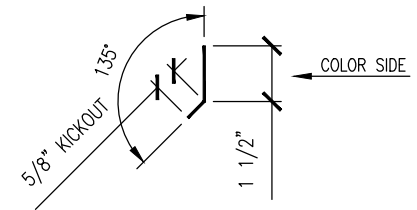
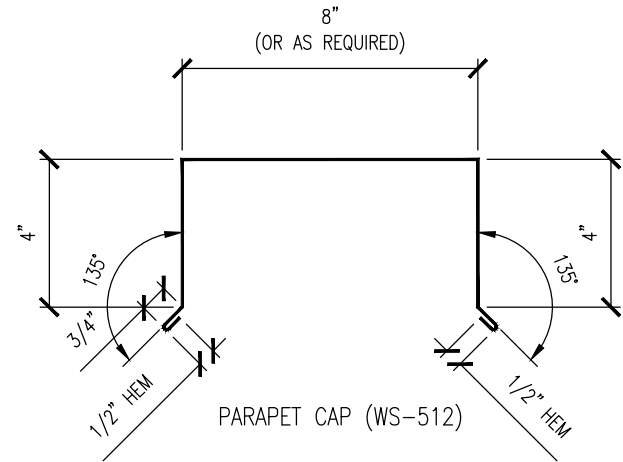
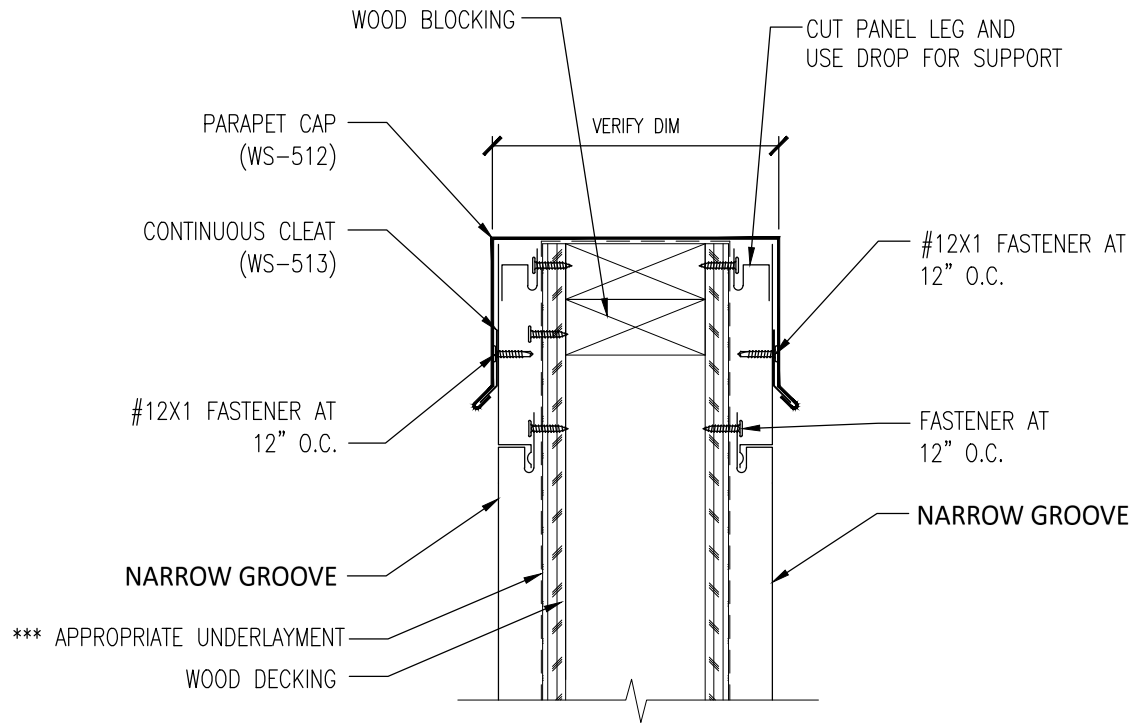

CONTINUOUS CLEAT (WS-513)

*** WSMR RECOMMENDS SHARKSKIN®ULTRA OR SHARKSKIN®ULTRA SA

Western States Metal Roofing

901 W. Watkins St.
 Phoenix, AZ 85007
 www.MetalForRoofing.com
 www.RustedRoofing.com
 www.MetalDeck.com

Phone: (602) 495-0048
 Fax: (602) 261-7726
 877-PURLINS (787-5467)

GAUGE: _____	COLOR: _____	
LENGTH: _____	FINISH: _____	
MATERIAL: _____		
PARAPET WALL HORIZONTAL DETAIL	A	5/15/22
	REV:	DATE:
PANEL TYPE: NARROW_GROOVE / T-GROOVE®	DETAIL #: TG-WSD-W19 25	

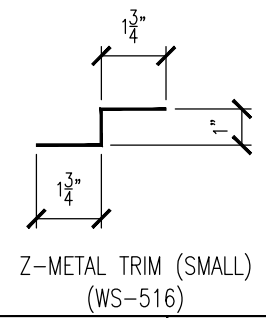
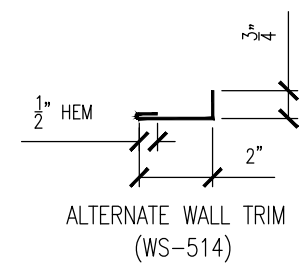
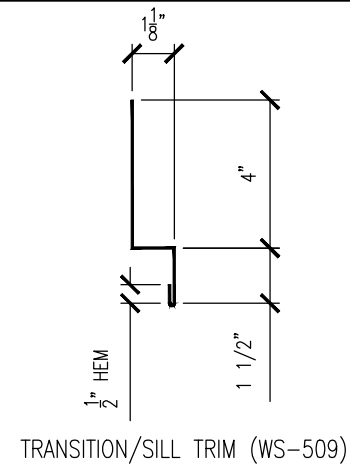
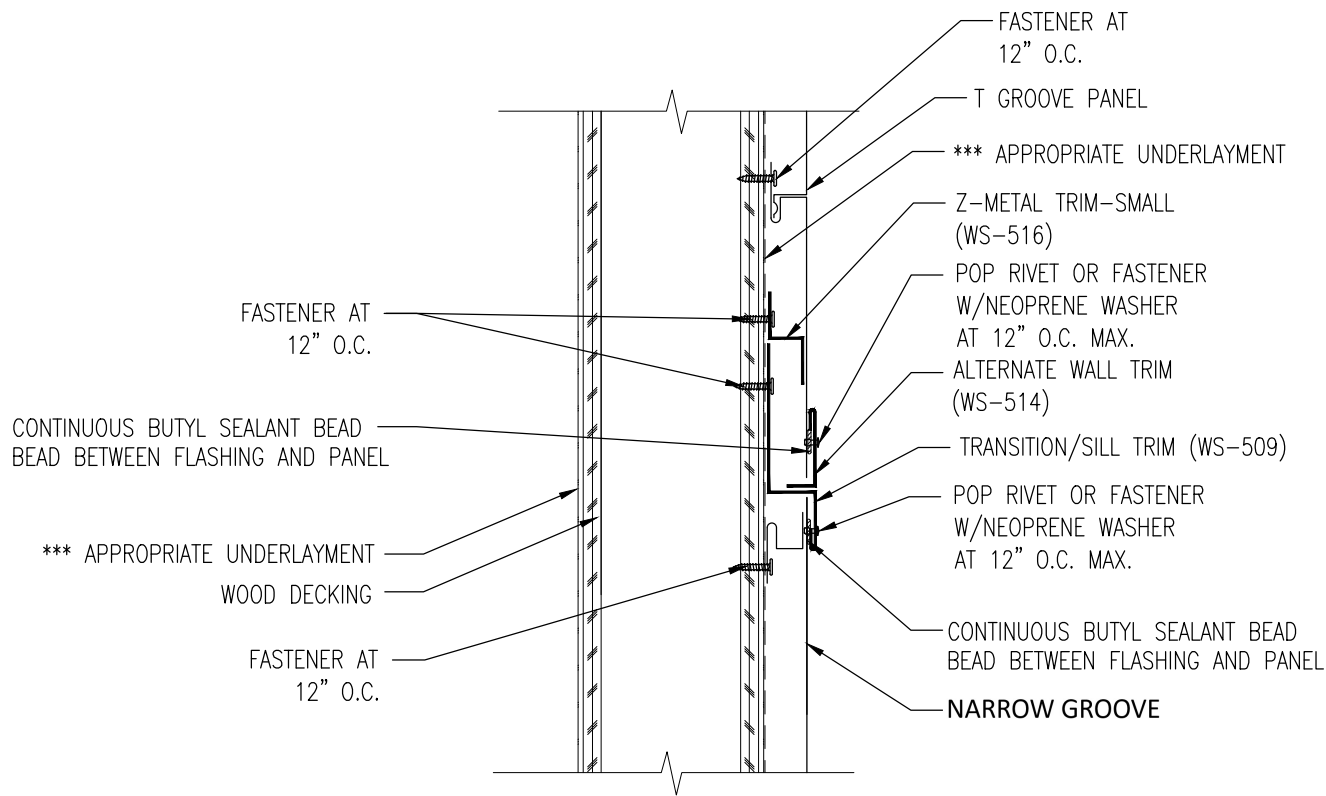

*** WSMR RECOMMENDS SHARKSKIN®ULTRA OR SHARKSKIN®ULTRA SA

GAUGE: _____	COLOR: _____
LENGTH: _____	FINISH: _____
MATERIAL: _____	

Western States Metal Roofing

901 W. Watkins St. Phone: (602) 495-0048
 Phoenix, AZ 85007 Fax: (602) 261-7726
 www.MetalForRoofing.com 877-PURLINS (787-5467)
 www.RustedRoofing.com
 www.MetalDeck.com

SPLICE/SILL HORIZONTAL DETAIL		
	A	5/15/22
PANEL TYPE: NARROW GROOVE	REV:	DATE:
	DETAIL #: TG-WSD-W20	

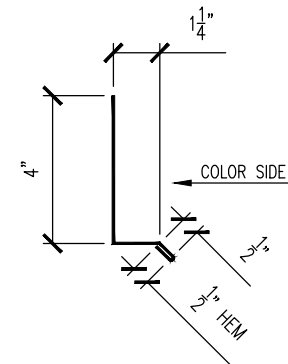
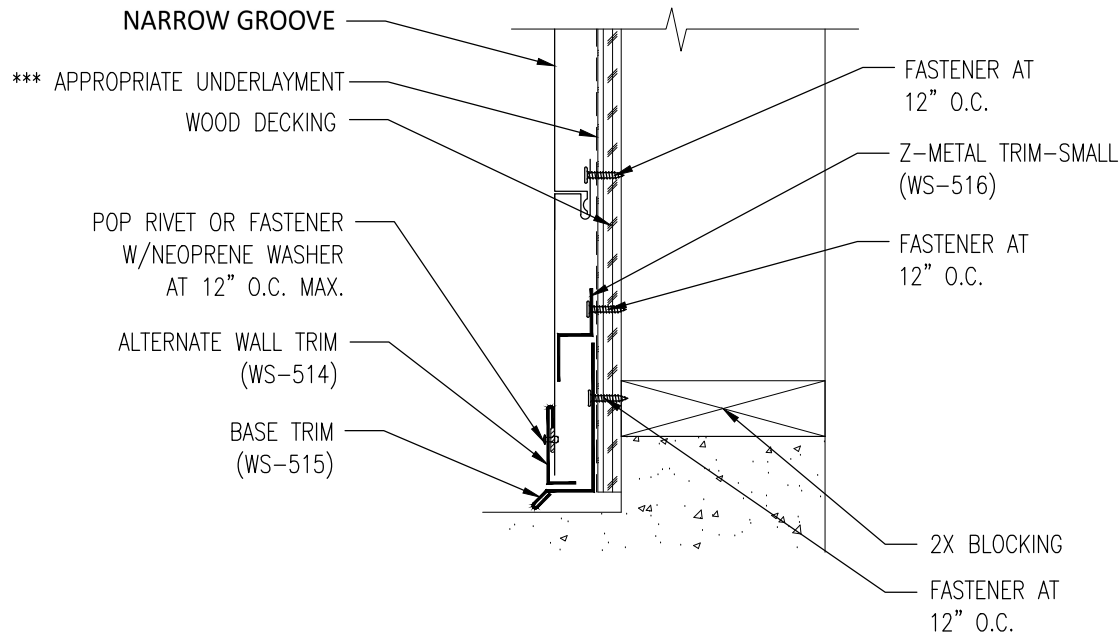

BASE TRIM
(WS-515)

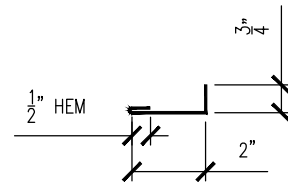

ALTERNATE WALL TRIM
(WS-514)

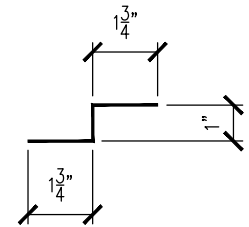

Z-METAL TRIM (SMALL)
(WS-516)

*** WSMR RECOMMENDS SHARKSKIN® ULTRA OR SHARKSKIN® ULTRA SA

GAUGE: _____	COLOR: _____
LENGTH: _____	FINISH: _____
MATERIAL: _____	

Western States Metal Roofing

901 W. Watkins St.
Phoenix, AZ 85007
www.MetalForRoofing.com
www.RustedRoofing.com
www.MetalDeck.com

Phone: (602) 495-0048
Fax: (602) 261-7726
877-PURLINS (787-5467)

BASE HORIZONTAL DETAIL		
	A	5/15/22
PANEL TYPE: NARROW GROOVE	REV:	DATE:
	DETAIL #: TG-WSD-W21	

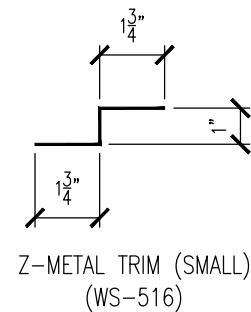
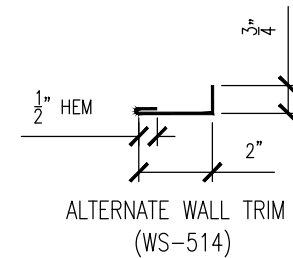
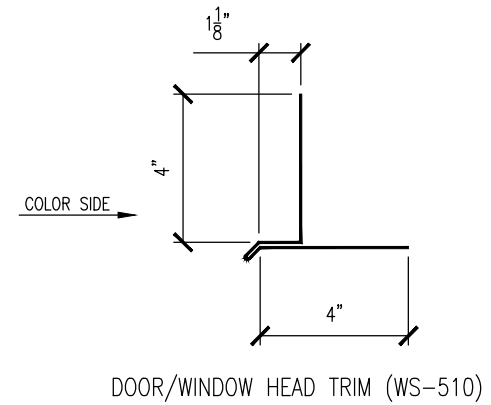
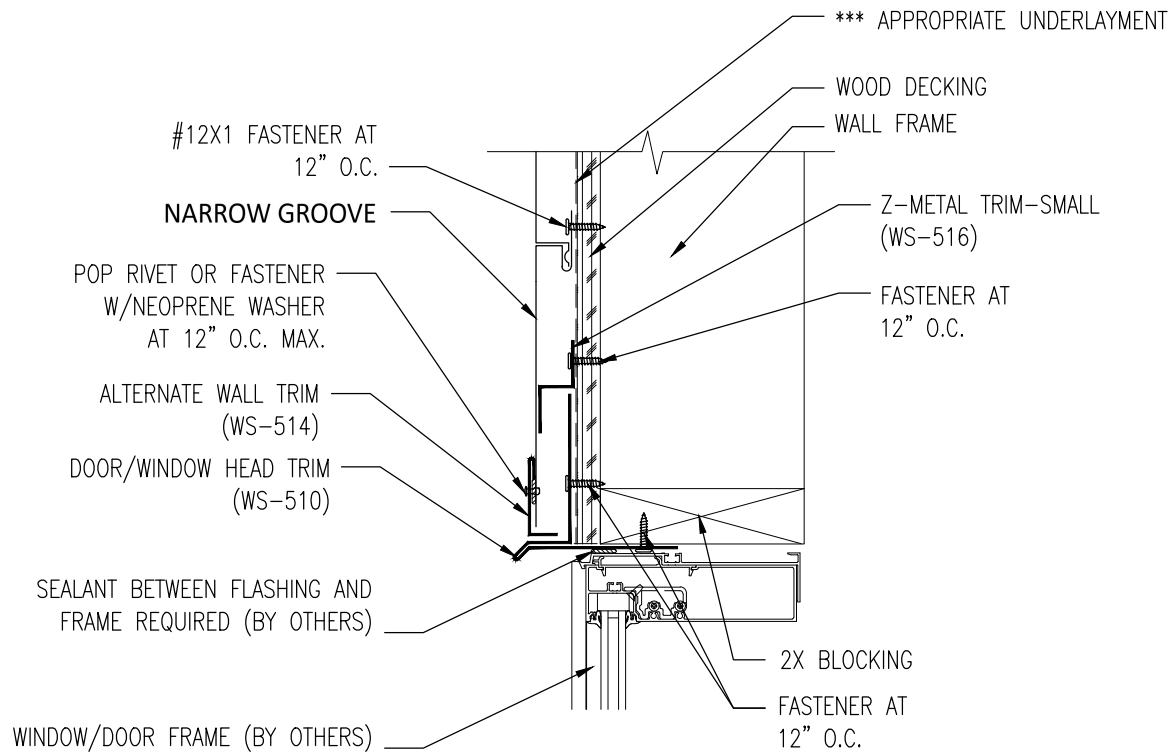

*** WSMR RECOMMENDS SHARKSKIN®ULTRA OR SHARKSKIN®ULTRA SA

GAUGE: _____	COLOR: _____	
LENGTH: _____	FINISH: _____	
MATERIAL: _____		
WINDOW/DOOR HEAD HORIZONTAL DETAIL	A	5/15/22
	REV:	DATE:
PANEL TYPE: NARROW GROOVE	DETAIL #: TG-WSD-W22	

Western States Metal Roofing

901 W. Watkins St.
Phoenix, AZ 85007
www.MetalForRoofing.com
www.RustedRoofing.com
www.MetalDeck.com

Phone: (602) 495-0048
Fax: (602) 261-7726
877-PURLINS (787-5467)

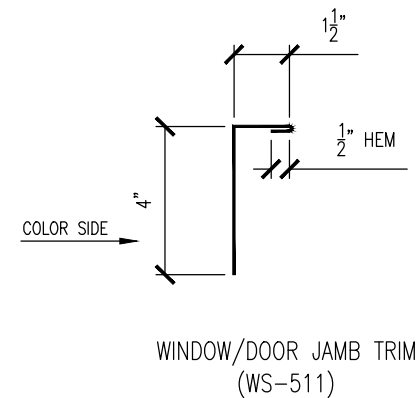
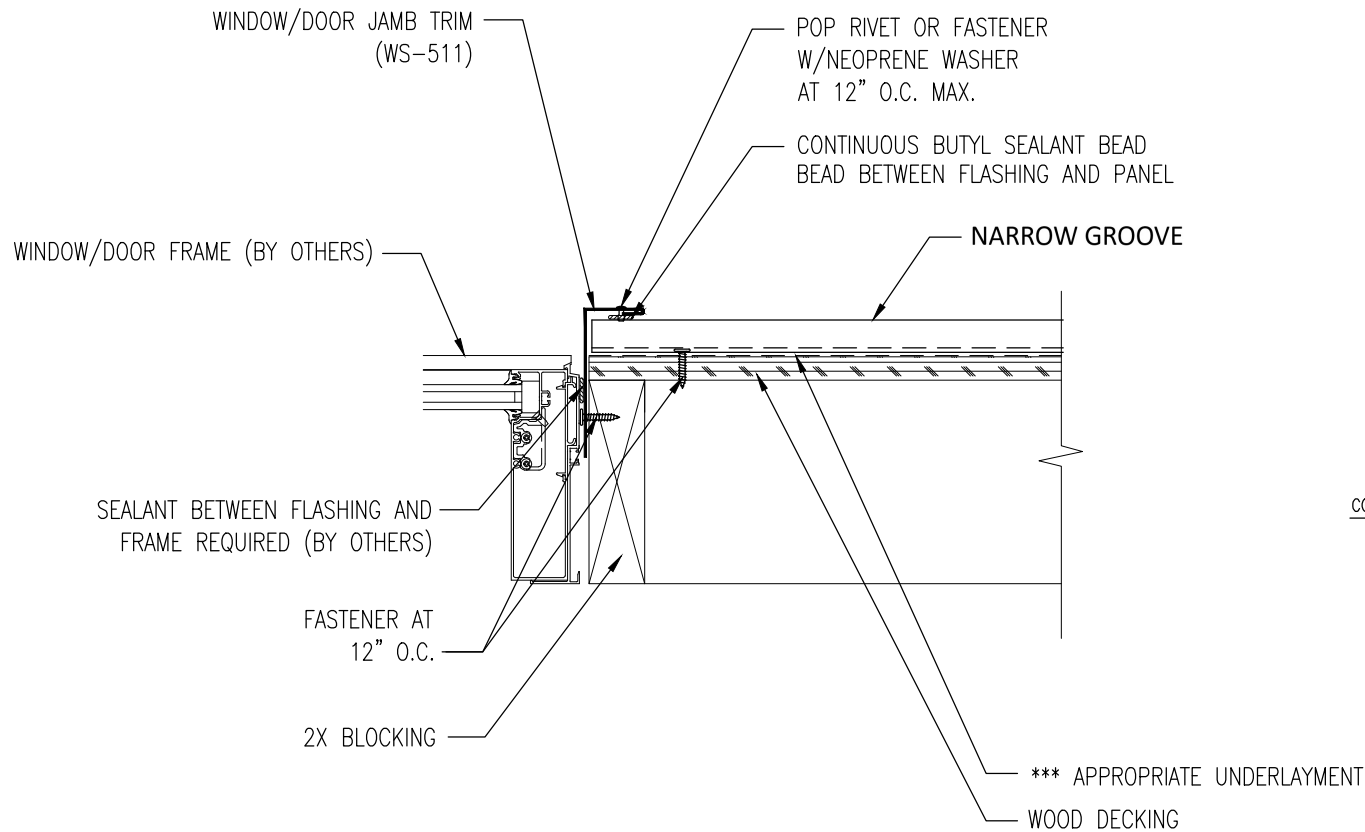

*** WSMR RECOMMENDS SHARKSKIN®ULTRA OR SHARKSKIN®ULTRA SA

GAUGE: _____	COLOR: _____		
LENGTH: _____	FINISH: _____		
MATERIAL: _____			
WINDOW/DOOR JAMB HORIZONTAL DETAIL		A	5/15/22
		REV:	DATE:
PANEL TYPE:	NARROW GROOVE	DETAIL #:	
		TG-WSD-W23	

Western States Metal Roofing

901 W. Watkins St.
 Phoenix, AZ 85007
www.MetalForRoofing.com
www.RustedRoofing.com
www.MetalDeck.com

Phone: (602) 495-0048
 Fax: (602) 261-7726
 877-PURLINS (787-5467)

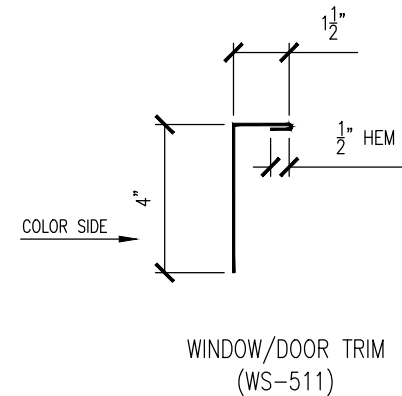
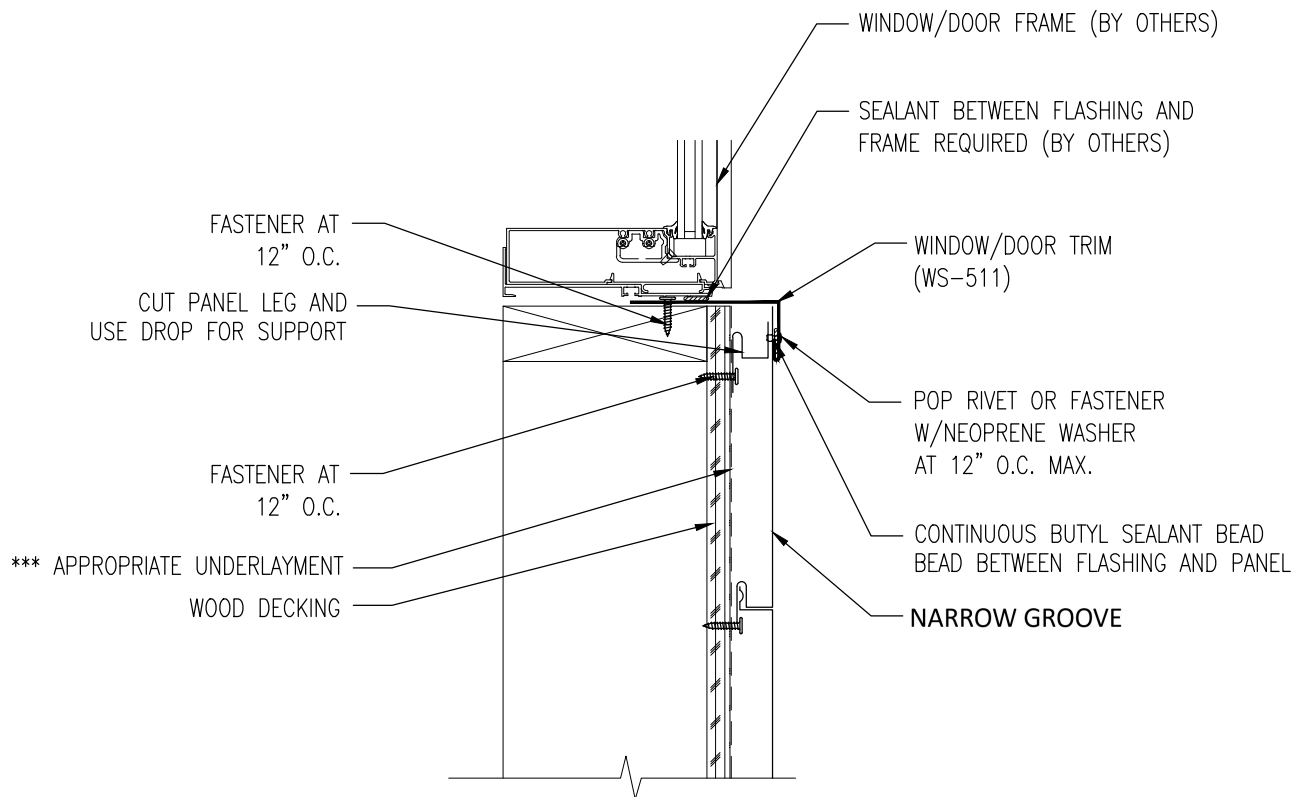

*** WSMR RECOMMENDS SHARKSKIN® ULTRA OR SHARKSKIN® ULTRA SA

Western States Metal Roofing

901 W. Watkins St.
 Phoenix, AZ 85007
www.MetalForRoofing.com
www.RustedRoofing.com
www.MetalDeck.com

Phone: (602) 495-0048
 Fax: (602) 261-7726
 877-PURLINS (787-5467)

GAUGE: _____		COLOR: _____	
LENGTH: _____		FINISH: _____	
MATERIAL: _____			
WINDOW/DOOR SILL HORIZONTAL DETAIL		A	5/15/22
		REV:	DATE:
PANEL TYPE: NARROW GROOVE		DETAIL #: TG-WSD-W24	

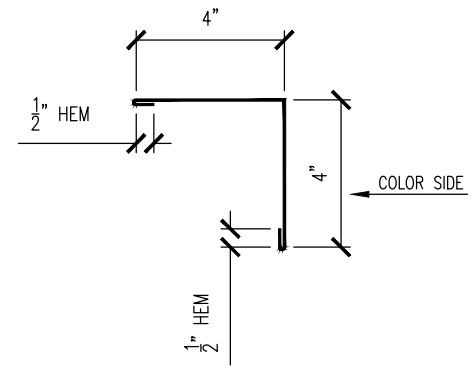
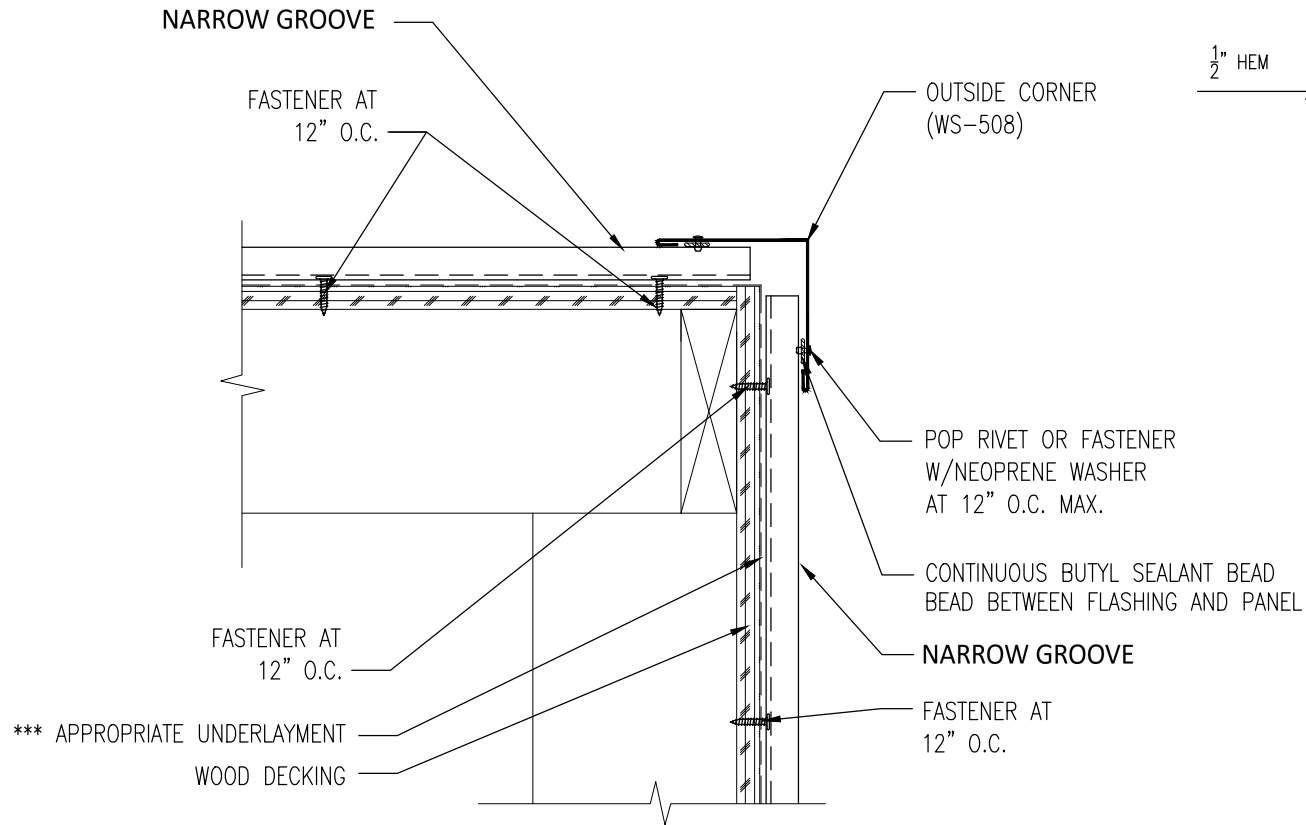

OUTSIDE CORNER (WS-508)

*** WSMR RECOMMENDS SHARKSKIN® ULTRA OR SHARKSKIN® ULTRA SA

GAUGE: _____	COLOR: _____
LENGTH: _____	FINISH: _____
MATERIAL: _____	

Western States Metal Roofing

901 W. Watkins St.
 Phoenix, AZ 85007
www.MetalForRoofing.com
www.RustedRoofing.com
www.MetalDeck.com

Phone: (602) 495-0048
 Fax: (602) 261-7726
 877-PURLINS (787-5467)

OUTSIDE CORNER HORIZONTAL DETAIL		
	A	5/15/22
PANEL TYPE: NARROW GROOVE	REV:	DATE:
	DETAIL #: TG-WSD-W25	

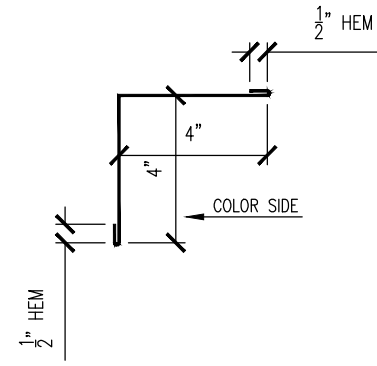
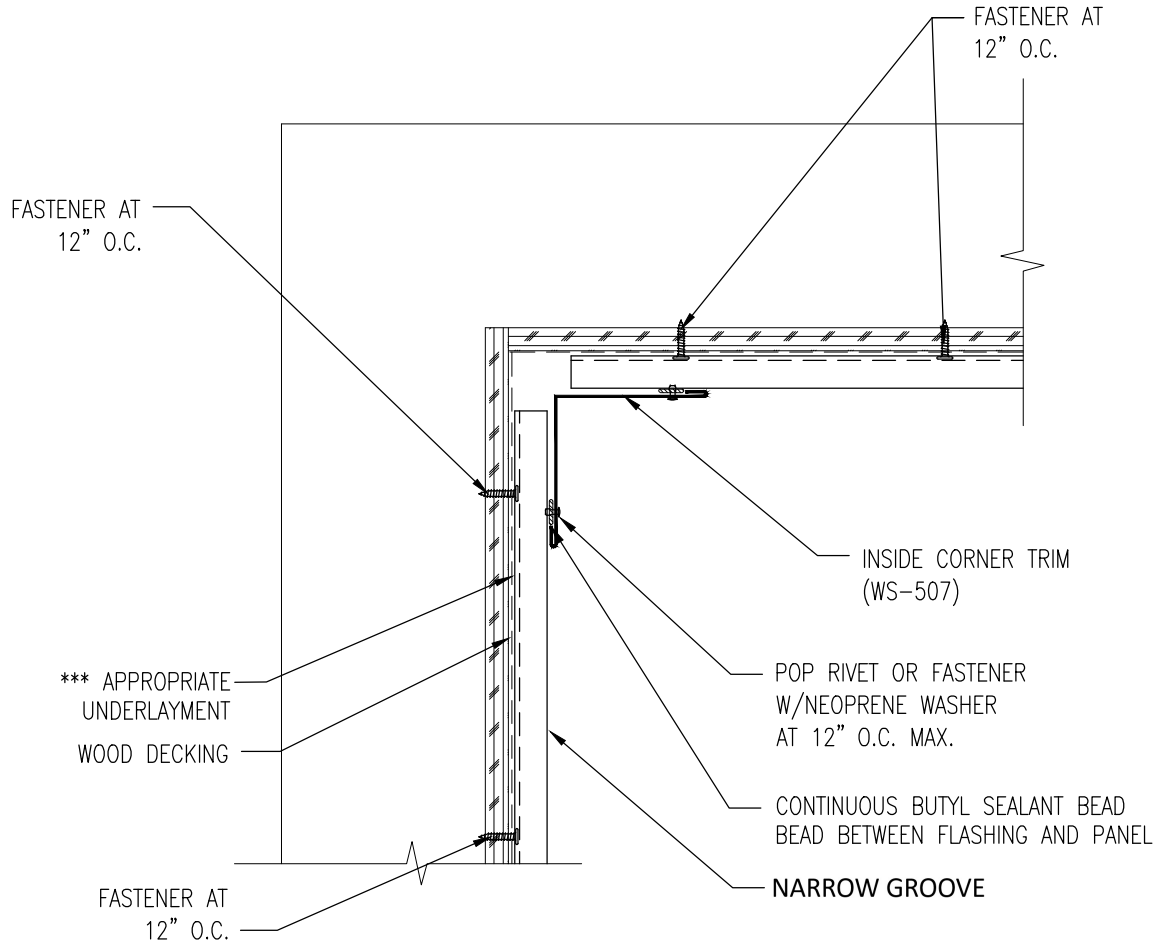

INSIDE CORNER TRIM (WS-507)

*** WSMR RECOMMENDS SHARKSKIN®ULTRA OR SHARKSKIN®ULTRA SA

GAUGE: _____	COLOR: _____
LENGTH: _____	FINISH: _____
MATERIAL: _____	

Western States Metal Roofing

901 W. Watkins St.
 Phoenix, AZ 85007
www.MetalForRoofing.com
www.RustedRoofing.com
www.MetalDeck.com

Phone: (602) 495-0048
 Fax: (602) 261-7726
 877-PURLINS (787-5467)

INSIDE CORNER HORIZONTAL DETAIL		
	A	5/15/22
PANEL TYPE: NARROW GROOVE	REV:	DATE:
	DETAIL #: TG-WSD-W26	

NOTES:

Western States Metal Roofing

901 W. Watkins St.
Phoenix, AZ 85007
www.MetalForRoofing.com
www.RustedRoofing.com
www.MetalDeck.com

Phone: (602) 495-0048
Fax: (602) 261-7726
877-PURLINS (787-5467)

NOTES

PANEL TYPE:

NARROW GROOVE

A 5/15/22

REV: DATE:

DETAIL #:
TG-WSD-MN27

CUSTOM TRIM

GAUGE: _____	COLOR: _____	
BREAKS: _____	FINISH: _____	
LENGTH: _____	STRETCH OUT: _____	
MATERIAL: _____		
CUSTOM TRIM NAME: _____		
	A	5/15/22
PANEL TYPE: NARROW GROOVE	REV:	DATE:
	DETAIL #: TG-WSD-CT28	

Western States Metal Roofing

901 W. Watkins St.
 Phoenix, AZ 85007
www.MetalForRoofing.com
www.RustedRoofing.com
www.MetalDeck.com

Phone: (602) 495-0048
 Fax: (602) 261-7726
 877-PURLINS (787-5467)

Narrow Grove

Installation, Flashings & Shop Drawing Detail Guide

Special Design Considerations

The details contained in this guide are proven industry details and are intended to be used as a design aid and installation guide. It does not depict all situations that may be encountered on all projects. Modifications are the responsibility of the designer/ owner/ installer.

Consideration should be given for Fit for Purpose, Building use, Climate conditions such as temperature, snow, wind, and moisture, Governing Building Codes, and Maintenance.

It is highly recommended that all trims and flashings be of the same material as the panels (metal, gauge, finish) to ensure long term performance and durability. Where possible, flashing edges should be hemmed to strengthen the edge and protect the cut edge from exposure.

Acceptance

Use of this manual is strictly voluntary. Details that are provided are to be used as a guide only. Details may not be applicable for all situations. This guide provides one standard detail and WSDI accepts that other installation details may be needed and other details may exist. WSDI makes no guarantee as to the Weather Tightness of the system or details found within this guide. The information in this manual is believed to be correct and accurate at the time of printing. WSDI reserves the right to change details, discontinue products, change designs at any time without incurring obligation. It is best to consult your Design Engineer for recommendations.

Underlayment

There are many types of underlayment's on the market today. All designed with a special purpose depending on the type of Metal and profile. Many different types of metal will require a different type of underlayment, such as A606-4 (Corten) which requires a High Temperature underlayment. WSMR recommends Sharkskin® Ultra and/or Sharkskin® Ultra SA.

Snow Design

Design and dimension must be the proper width to accommodate high snow, rain, ice, and slope conditions. If possible, splices, penetrations, should be minimized in areas of high snow and ice accumulations. Details found in this manual may not pertain in areas of high snow and ice accumulations.

Panel Coverage and Fastening

T-Groove is available in the following panel widths: 12", 14", 16" and 18" wide. It can also be made with up to a 3" reveal. Custom panel widths are available. Please consult with your WSMR representative for details and fastening recommendations.

Safety and Maintenance

Extreme care should always be used when working with metals. Safety should always be a top priority and approved fall protection and equipment as approved by OSHA should always be used.

No structure is immune to severe weather or is completely maintenance free. To keep your siding performing as it was designed, an inspection and comprehensive maintenance program should be implemented.

References

For other installation techniques and details, The Sheet Metal and Air Conditioning Contractors National Association Inc. (SMACNA) and NRCA manuals are great resource for working with sheet metal.

Technical Assistance

Contact your WSDI sales or technical representative for any additional information or assistance. To insure you have the latest information available, please inquire or visit our web sites at www.Westernstatesmetalroofing.com or www.Paintedtrustedroofing.com



Finishes You've Never Seen Before®

WESTERN STATES METAL ROOFING

(877) 787-5467 • WESTERNSTATESMETALROOFING.COM

REQUEST A FREE METAL COLOR SAMPLE

Affordable Delivery throughout USA, Canada, and Mexico

Phoenix: 901 W Watkins St., Phoenix, AZ 85007

☎ (602) 495-0048

✉ sales@westernstatesmetalroofing.com

Tucson: 4975 E. Drexel Rd., Tucson, AZ 85706

☎ (520) 574-4247

✉ tucsonsales@westernstatesmetalroofing.com



www.facebook.com/westernstatesmetalroofing/



www.instagram.com/westernstatesmetalroofing/



www.twitter.com/weststatesmetal



www.youtube.com/westernstatesmetalroofing



www.linkedin.com/company/western-states-metal-roofing



www.pinterest.com/westernstatesmetalroofing/



www.houzz.com/pro/raynaann/western-states-metal-roofing